



TABLE OF CONTENTS

THE NEW GENERATION OF A PROVEN CONCEPT (RTS)	2-3
ALTUS (RTS)	4
THE SOMFY MOTOR RANGE	5-8
DIMENSIONS	
SOMFY LV25/LW25/LT25/LT28 DC MOTORS	9
SOMFY LS40/LT50/LT60/FTS/SLT	10
SOMFY LT50/LT60 CMO, LT50 RH, LT50 ILT and LT50 ILT RH	11
SOMFY LT50 ALTUS RTS, LT50 OREA RTS AND LT50 RTS CMO	12
THE CONCEPT OF TORQUE	13
MOTOR SELECTION GUIDE	
For Retractable Awnings	14
MOTOR SELECTION GUIDE	
For Rolling Shutters	15-20
MOTOR SELECTION GUIDE	
For Roll-up Applications and Interior Window Coverings	21-22
SPECIAL APPLICATION MOTORS (ILT, FTS, SLT AND OREA RTS)	23-24
FTS MOTOR SELECTION GUIDE AND INSTALLATION INSTRUCTIONS	25-27
DC MOTOR MECHANICAL ACCESSORIES	28-31
DC MOTOR CORD TAKE-UP SYSTEMS (CTS)	32
LS40 MECHANICAL ACCESSORIES	33-36
LT50/60 MECHANICAL ACCESSORIES	
Motor Brackets	37-42
Idler Brackets	43-45
Intermediate Brackets	46
End Caps	47-48
Miscellaneous	49-51
Crowns and Drives	52-54
CMO CABLES AND MECHANICAL ACCESSORIES	55-58
LT50/60 AND LT50/60 CMO MECHANICAL ACCESSORY KITS	59-60
INSTALLATION INSTRUCTIONS	
LT Range	61
LS40, LT50/60, LT50 RH,	62-64
LT50/60 CMO and LT50 RTS CMO Motors	65
ILT and SLT Motors	66
ALTUS RTS AND OREA RTS MOTOR LIMIT SETTING INSTRUCTIONS	67-70
OPERATOR WIRING INSTRUCTIONS	71
OPERATOR WIRING CONSIDERATIONS	72
CATALOG NUMBER INDEX	73-78



(RTS) Radio Technology SOMFY™ The New Generation of a Proven Concept

The SOMFY LT RTS (Radio Technology Somfy™) motor line combines the quality characteristics of the previous tubular motors which have proven themselves a million times over, with innovative design and optimal technical features. The reliability, sturdy construction and maintenance free aspects of SOMFY motors have remained the same. The new Radio (RTS) concept offers you significantly easier motor selection, simple installation, plug-in wire connections and remote limit switch adjustments.

The advanced design and technical innovations contribute to reducing installation time and costs which are important to both you and your customers.

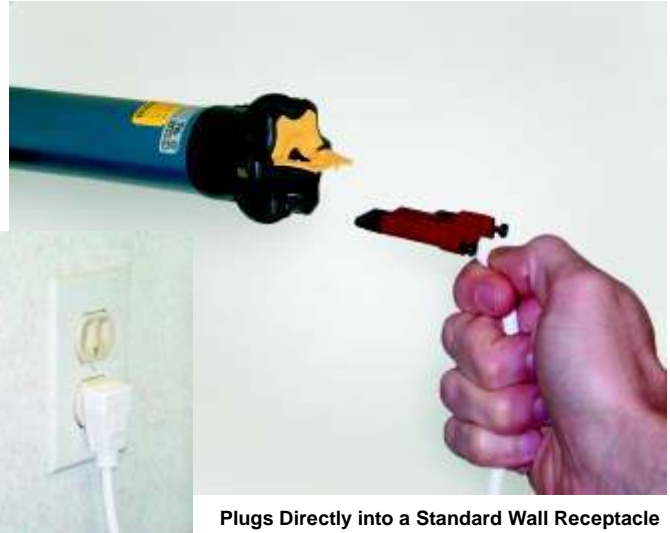

Plugs Directly into a Standard Wall Receptacle



Minimum Labor Required: New Motor Mounting featuring motor bracket with spring and capability of 6 different installation positions



Convenience of remote limit adjustment set via the hand held transmitter (for Altus RTS)



Minimum "Side" Space Requirement: only 23mm

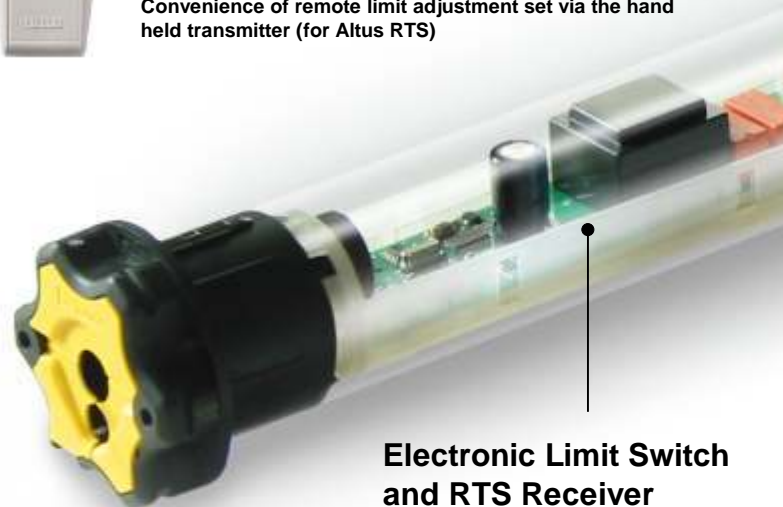

Electronic Limit Switch and RTS Receiver

SOMFY LT RTS Motors at a Glance

1. The Right Motor Solution for Every Job, Due to a Wide Range of Models

- Expanded product line in terms of lifting capacity and operating speed
- First manual override motor with built-in radio technology "CMO RTS".

2. Quick and Easy Installation

- Reduced number of mechanical accessories
- Can be installed in 6 different positions
- Minimum side space requirement (23mm)
- Motor and drive are attached with a simple click connection (no screws required)

3. Convenience for the End User

- Features quiet operation due to the use of advanced product components

5. Easy Limit Switch Setting

- Limits are set via remote radio transmitter

6. All SOMFY Motors are UL and CSA Recognized

- SOMFY UL Recognized motors can be found in the following file numbers: E60495, E60888, E63714



4. Simple Electrical Connection

- New UL approved 5-15P Nema plug-in motor cable simplifies electrical connections
- Plugs into a standard electrical receptacle and eliminates the need for an electrician
- Motor cable length can be customized to meet your installation requirements



Innovative: Drive is attached with a simple click on connection.



Radio Technology Somfy™ (RTS) Motors

Altus RTS

With RTS (Radio Technology Somfy™), installation and user operation has been simplified and the overall performance of motorized window coverings, projection screens, awnings and rolling shutters have been enhanced. Designed with all of the great features of SOMFY's popular LT motors, the Altus RTS motor shares one important distinction... A radio remote control receiver is built into the motor providing the user with remote control capabilities without added wiring.

With the Altus RTS motor the end user can have wireless control over any motorized window covering via a radio remote control transmitter or a Decora RTS wireless wall switch within a range of up to 90 feet in open space and up to 65 feet through two concrete walls. The RTS motor can be parallel wired which eliminates the need to connect switches and to access a control device. It also eliminates long wire runs which are often time consuming and expensive.



DECORA RTS 4
WIRELESS
WALL SWITCH

The Altus RTS motor features a user programmable intermediate stop position and operates on a narrow bandwidth that is less susceptible to interference (433.42 MHz). The RTS system also features 16 million rolling codes to provide for maximum security.

The Telis RTS transmitters and Decora RTS wireless wall switches enable a user to program individual, group and master control to optimize operational convenience and to customize the system to meet virtually any design requirement.

The Altus RTS motor is compatible with the RTS sun and wind sensors to provide a measure of protection when used with retractable awnings.

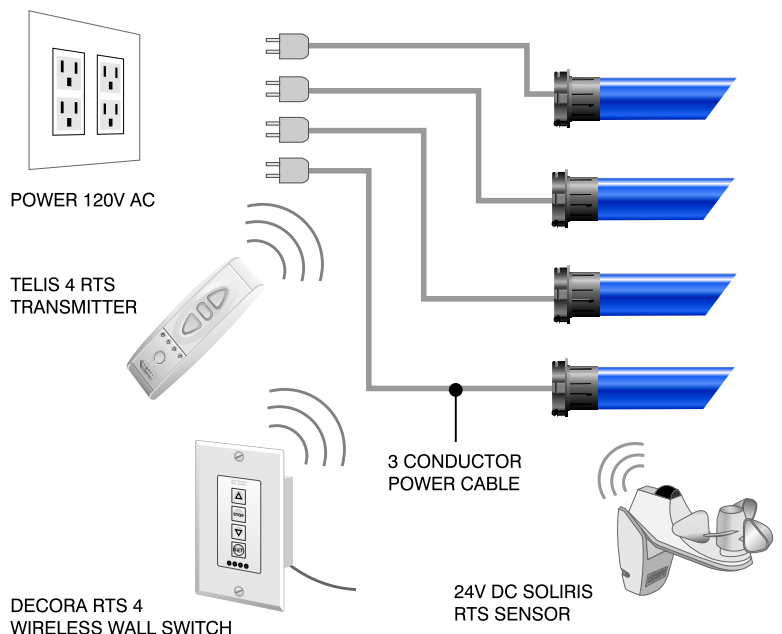

NOTE: Refer to page 67 of this catalog for limit setting instructions.



The SOMFY DC Motor Range

Technical Specifications

LV 25 Range - Single Shaft Drive

MOTOR TYPE	NOMINAL TORQUE		SPEED rpm	ELECTRICAL RATING		WEIGHT		THEORETICAL LIFTING CAPACITY*	
	in. lb.	Nm		Volt	Ampere	lb.	kg.	lb.	kg.
LV 25-B44	3.52	0.4	40	24DC	450mA	.322	.145	*	*
LV 25-B64	5.28	0.6	35	24DC	500mA	.322	.145	*	*

LW 25 Range - Double Shaft Drive

MOTOR TYPE	NOMINAL TORQUE		SPEED rpm	ELECTRICAL RATING		WEIGHT		THEORETICAL LIFTING CAPACITY*	
	in. lb.	Nm		Volt	Ampere	lb.	kg.	lb.	kg.
LW 25-B44	3.52	0.4	40	24DC	450mA	.432	.195	*	*
LW 25-B83	7.04	0.8	30	24DC	650mA	.432	.195	*	*

LT 28 Range

MOTOR TYPE	NOMINAL TORQUE		SPEED rpm	ELECTRICAL RATING		WEIGHT		THEORETICAL LIFTING CAPACITY*	
	in. lb.	Nm		Volt	Ampere	lb.	kg.	lb.	kg.
LT28 A	6.16	.7	34	12VDC	750mA	.6	.27	8.8	4
LT28 AF	6.16	.7	34	12VDC	750mA	.6	.27	8.8	4
LT28 B	6.16	.7	34	24VDC	380mA	.6	.27	8.8	4

* See chart on page 22 for Product Applications/ Lifting Specifications



The SOMFY AC Motor Range

Motor Names

It is easy to understand these names as they follow the logical order of increasing torque and have a letter indicating the application (speed).

Conversion Factor:
1 Nm = 8.8 in. lbs.

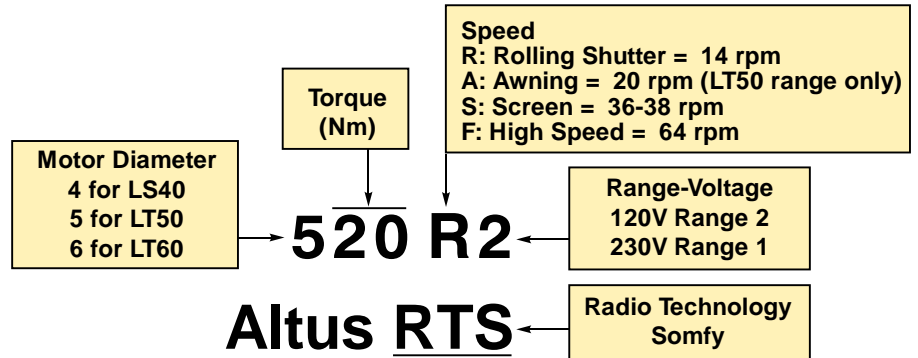

* **Important information which must be understood before using the following technical specifications.**

SOMFY motors are not designed for continuous operation. They are equipped with a built-in thermal overload protector which limits their operation to intermittent use only... in accordance with Underwriter Laboratories, Inc. and Canadian Standards Association specifications. Maximum running time is approximately 5 minutes depending upon operating conditions. Although SOMFY motors are designed for indoor and outdoor use, they must be protected from direct weather elements such as: rain, sleet, etc...

Theoretical Lifting Capacity does not take into account any systems losses and should be used only as a reference. For the definition of "Theoretical Lifting Capacity" please refer to page 13. The actual lifting capacity of the particular motor depends on other factors such as tube diameter used and its length, selection of motor accessories (brackets, end caps, etc...), and mounting method used. Please consult SOMFY Systems for assistance with determining the actual lifting capacity of SOMFY motors in your particular application.

Technical Specifications

LS40 Range - Round Head Progressive Limit Switch Unit

MOTOR TYPE (4mm Allen Screw Limit)	NOMINAL TORQUE		SPEED	ELECTRICAL RATING				LIMIT SWITCH CAPACITY	WEIGHT		THEORETICAL LIFTING CAPACITY*	
	in. lb.	Nm	rpm	Volt	Hz	Ampere	Watt	# Rotations	lb.	kg.	lb.	kg.
404R2	35	4	16	120	60	0.8	85	40	2.11	0.95	44.0	20
409R2	79	9	16	120	60	1.2	135	40	2.38	1.08	100.0	45
404S2	35	4	36	120	60	0.9	100	40	1.92	0.95	44.0	20
401F2	11	1.3	64	120	60	.85	75	40	2.10	0.95	14.0	6.4
412R2	105	12	8	120	60	1.2	135	40	2.38	1.08	132	60

* Theoretical lifting capacity given on a 40mm (1.57") tube. Length and tube deflection will determine its load capacity.

LT50 Range - Rapid Push Button Limits

The LT50 range offers up to a 50Nm (440 in. lb.) model and a range of 14-38 rpm for all standard models, and 14 or 20 rpm for CMO versions.

MOTOR TYPE	NOMINAL TORQUE		SPEED	ELECTRICAL RATING				LIMIT SWITCH CAPACITY	WEIGHT		THEORETICAL LIFTING CAPACITY*	
	in. lb.	Nm	rpm	Volt	Hz	Ampere	Watt	# Rotations	lb.	kg.	lb.	kg.
504S2	35	4	38	120	60	0.7	80	46	3.8	1.72	35	16
504S2RH	35	4	38	120	60	0.7	80	46	3.8	1.72	35	16
505F2RH	44	5	64	120	60	1.25	145	46	4.4	2	44	20
506S2	53	6	38	120	60	0.95	110	46	4.1	1.87	53	24
506S2RH	53	6	38	120	60	0.95	110	46	4.1	1.87	53	24
510S2	88	10	38	120	60	1.3	150	46	4.41	2	88	40
510S2RH	88	10	38	120	60	1.3	150	46	4.41	2	88	40
510R2	88	10	14	120	60	0.7	80	46	3.8	1.72	88	40

* Please refer to Definition of Theoretical Lifting Capacity on page 13.



LT50 Range - Rapid Push Button Limits (Cont'd)

The LT50 range offers up to a 50Nm (440 in. lb.) model and a range of 14-38 rpm for all standard models, and 14 or 20 rpm for CMO versions.

MOTOR TYPE	NOMINAL TORQUE		SPEED rpm	ELECTRICAL RATING				LIMIT SWITCH CAPACITY # Rotations	WEIGHT		THEORETICAL LIFTING CAPACITY*	
	in. lb.	Nm		Volt	Hz	Ampere	Watt		lb.	kg.	lb.	kg.
515S2	132	15	38	120	60	1.8	210	46	5.62	2.55	132	60
515S2RH	132	15	38	120	60	1.8	210	46	5.62	2.55	132	60
515A2	132	15	20	120	60	1.1	130	46	4.3	1.95	132	60
520R2	176	20	14	120	60	1.1	130	46	4.3	1.95	176	80
525A2	220	25	20	120	60	1.6	180	46	4.74	2.15	220	100
525A2 CMO	220	25	20	120	60	1.6	180	34	7.14	3.24	220	100
530R2	264	30	14	120	60	1.5	170	46	4.74	2.15	264	120
530R2 CMO	264	30	14	120	60	1.5	170	34	7.14	3.24	264	120
535A2	308	35	20	120	60	2.1	250	46	5.62	2.55	308	140
535A2 CMO	308	35	20	120	60	2.1	250	34	7.69	3.49	308	140
540R2	352	40	14	120	60	1.8	210	46	5.62	2.55	352	160
540R2 CMO	352	40	14	120	60	1.8	210	34	7.69	3.49	352	160
550R2	440	50	14	120	60	2.1	250	46	5.62	2.55	440	200
550R2 CMO	440	50	14	120	60	2.1	250	34	7.69	3.49	440	200

SLT (for Cassette Awnings) - Star Head Rapid Push Button Limits

MOTOR TYPE	NOMINAL TORQUE		SPEED rpm	ELECTRICAL RATING				LIMIT SWITCH CAPACITY # Rotations	WEIGHT		THEORETICAL LIFTING CAPACITY*	
	in. lb.	Nm		Volt	Hz	Ampere	Watt		lb.	kg.	lb.	kg.
525A2 SLTL	220	25	20	120	60	1.6	180	46	5.5	2.5	220	100
525A2 SLTR	220	25	20	120	60	1.6	180	46	5.5	2.5	220	100
535A2 SLTL	308	35	20	120	60	2.1	250	46	6.4	2.9	308	140
535A2 SLTR	308	35	20	120	60	2.1	250	46	6.4	2.9	308	140
660R2 SLTL	530	60	14	120	60	2.5	285	35	9.7	4.4	424	192
660R2 SLTR	530	60	14	120	60	2.5	285	35	9.7	4.4	424	192

L= Left Mount R= Right Mount

ILT - Electronic Limit Switch

MOTOR TYPE	NOMINAL TORQUE		SPEED rpm	ELECTRICAL RATING				LIMIT SWITCH CAPACITY # Rotations	WEIGHT		THEORETICAL LIFTING CAPACITY*	
	in. lb.	Nm		Volt	Hz	Ampere	Watt		lb.	kg.	lb.	kg.
506S2 ILT	52	6	38	120	60	.95	110	300	4.6	2.07	52	23.6
506S2 ILTRH	52	6	38	120	60	.95	110	300	4.6	2.07	52	23.6
515S2 ILT	132	15	38	120	60	1.8	210	300	6.1	2.77	132	60
515S2 ILTRH	132	15	38	120	60	1.8	210	300	6.1	2.77	132	60
535A2 ILT	308	35	20	120	60	2.1	250	300	6.1	2.77	308	140
535A2 ILTRH	308	35	20	120	60	2.1	250	300	6.1	2.77	308	140

* Please refer to Definition of Theoretical Lifting Capacity on page 13.



LT50 Altus RTS Range - Star Head Electronic Limit Switch

MOTOR TYPE	NOMINAL TORQUE		SPEED	ELECTRICAL RATING				LIMIT SWITCH CAPACITY	WEIGHT		THEORETICAL LIFTING CAPACITY*	
	in. lb.	Nm	rpm	Volt	Hz	Ampere	Watt	# Rotations	lb.	kg.	lb.	kg.
** 506S2 ALTUS RTS	53	6	38	120	60	1.1	125	250	4.58	2.08	53	24
** 510S2 ALTUS RTS	88	10	38	120	60	1.3	150	250	4.40	2.0	88	40
525A2 ALTUS RTS	220	25	20	120	60	1.6	180	250	4.73	2.15	220	100
530R2 ALTUS RTS	264	30	14	120	60	1.5	170	250	4.73	2.15	264	120
535A2 ALTUS RTS	308	35	20	120	60	2.1	240	250	6.10	2.77	308	140
540R2 ALTUS RTS	352	40	14	120	60	1.8	210	250	5.61	2.55	352	160
550R2 ALTUS RTS	440	50	14	120	60	2.1	240	250	5.61	2.55	440	200

** - Also available in an RH version

LT50 OREA RTS Range - Star Head Electronic Limit Switch

MOTOR TYPE	NOMINAL TORQUE		SPEED	ELECTRICAL RATING				LIMIT SWITCH CAPACITY	WEIGHT		THEORETICAL LIFTING CAPACITY*	
	in. lb.	Nm	rpm	Volt	Hz	Ampere	Watt	# Rotations	lb.	kg.	lb.	kg.
535A2 OREA RTS	308	35	20	120	60	2.1	240	250	6.1	2.77	308	140
550R2 OREA RTS	440	50	14	120	60	2.1	240	250	5.6	2.55	440	200

LT50 RTS CMO Range - Rapid Push Button Limits

MOTOR TYPE	NOMINAL TORQUE		SPEED	ELECTRICAL RATING				LIMIT SWITCH CAPACITY	WEIGHT		THEORETICAL LIFTING CAPACITY*	
	in. lb.	Nm	rpm	Volt	Hz	Ampere	Watt	# Rotations	lb.	kg.	lb.	kg.
525A2 RTS CMO	220	25	20	120	60	1.6	180	34	7.6	3.45	220	100
530R2 RTS CMO	264	30	14	120	60	1.5	170	34	7.12	3.24	264	120
535A2 RTS CMO	308	35	20	120	60	2.1	250	34	8.06	3.66	308	140
540R2 RTS CMO	352	40	14	120	60	1.8	210	34	7.72	3.51	352	160
550R2 RTS CMO	440	50	14	120	60	2.1	250	34	7.79	3.54	440	200

LT60 Range - Rapid Push Button Limits

The LT60 range offers up to a 100Nm (880 in. lb.) model, and 14 rpm for all models.

MOTOR TYPE	NOMINAL TORQUE		SPEED	ELECTRICAL RATING				LIMIT SWITCH CAPACITY	WEIGHT		THEORETICAL LIFTING CAPACITY*	
	in. lb.	Nm	rpm	Volt	Hz	Ampere	Watt	# Rotations	lb.	kg.	lb.	kg.
660R2	530	60	14	120	60	2.5	285	35	8.9	4.05	424	191
660R2 CMO	530	60	14	120	60	2.5	285	34	11.4	5.19	424	191
680R2	700	80	14	120	60	3.4	390	35	9.5	4.30	560	255
680R2 CMO	700	80	14	120	60	3.4	390	34	12.0	5.45	560	255
6100R2	880	100	14	120	60	3.8	430	35	10.3	4.70	700	317
6100R2 CMO	880	100	14	120	60	3.8	430	34	13.3	6.03	700	317

* Please refer to Definition of Theoretical Lifting Capacity on page 13.



Dimensions

SOMFY LV25/LW25/LT25 /LT28 DC MOTORS

LV 25

MOTOR TYPE
LV 25-B44
LV 25-B64

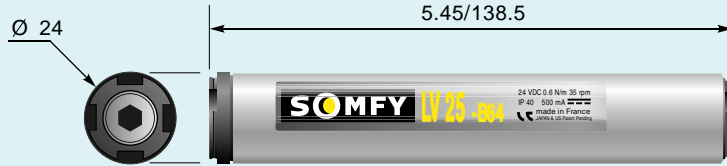

LW 25

MOTOR TYPE
LW 25-B44
LW 25-B83

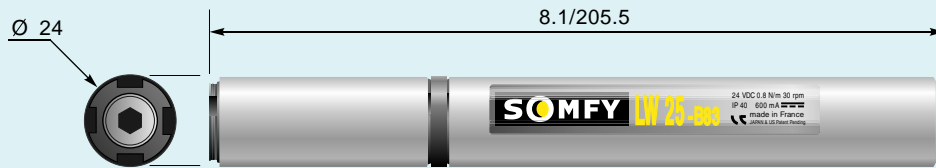

Dimensions are inches/mm

LT 28

MOTOR TYPE
LT 28A
LT 28B

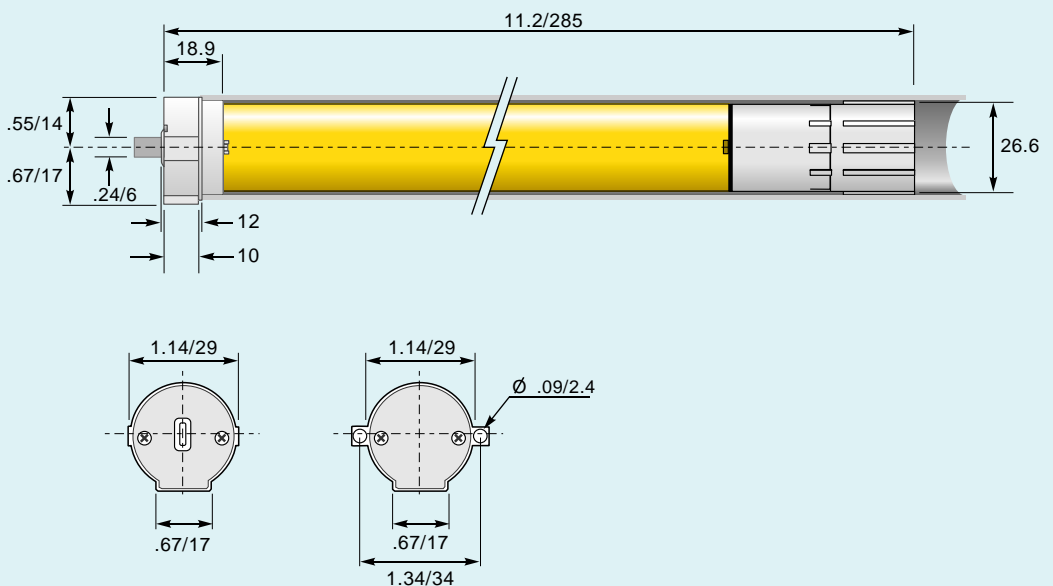

Note: LT28AF is a flush mount type

Dimensions are inches/mm

LS40

MOTOR TYPE
401F2
404R2
404S2
409R2
412R2

2 Mounting Holes for Self-Tapping Screw Dia. 4 mm (Cat. # 4000555) (Depth 9 mm), Spaced 1.14" (29 mm) Apart

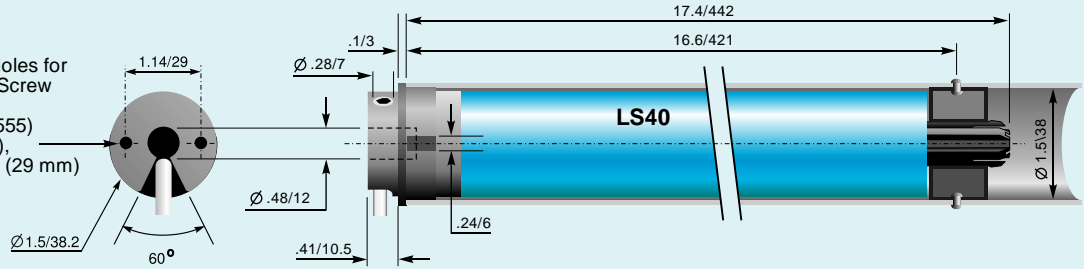

LT50

MOTOR TYPE	X in. / mm	Y in. / mm
504S2	19.88/505	19.29/490
506S2	20.67/525	20.08/510
510S2	21.85/555	21.26/540
510R2	19.88/505	19.29/490
515S2	23.82/605	23.23/590
515A2	20.67/525	20.08/510
520R2	20.67/525	20.08/510
525A2	21.85/555	21.26/540
530R2	21.85/555	21.26/540
535A2	23.82/605	23.23/590
540R2	23.82/605	23.23/590
550R2	23.82/605	23.23/590
LT50 FTS		
525A2 FTS	26.2/655	25.6/640

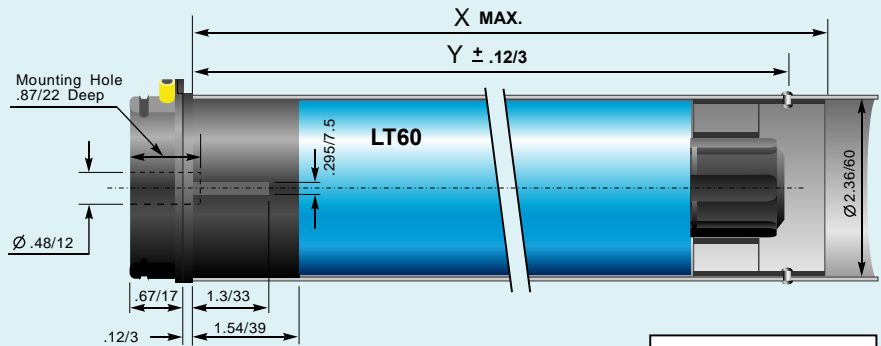
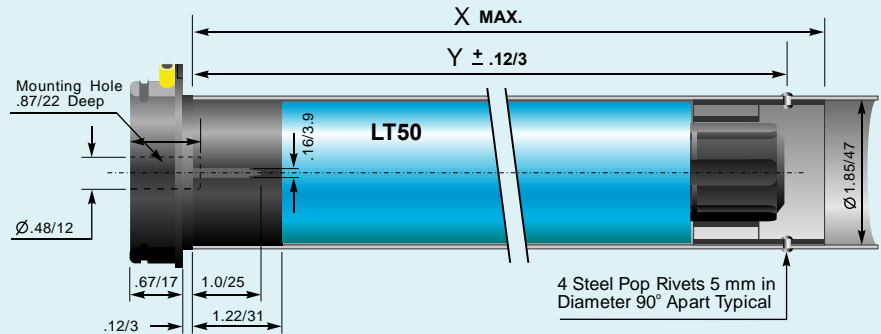

SLT50*

MOTOR TYPE	X in. / mm	Y in. / mm
525A2 SLTL	26.6/675	26.0/660
525A2 SLTR	26.6/675	26.0/660
535A2 SLTL	28.2/715	27.6/700
535A2 SLTR	28.2/715	27.6/700

LT60

MOTOR TYPE	X in. / mm	Y in. / mm
660R2	25.9/659	25.3/642
680R2	25.9/659	25.3/642
6100R2	25.9/659	25.3/642
LT60 FTS		
655A2 FTS	27.3/684	26.7/677

SLT60*

MOTOR TYPE	X in. / mm	Y in. / mm
660R2 SLTL	28.9/734	28.2/717
660R2 SLTR	28.9/734	28.2/717

LT50/60/FTS

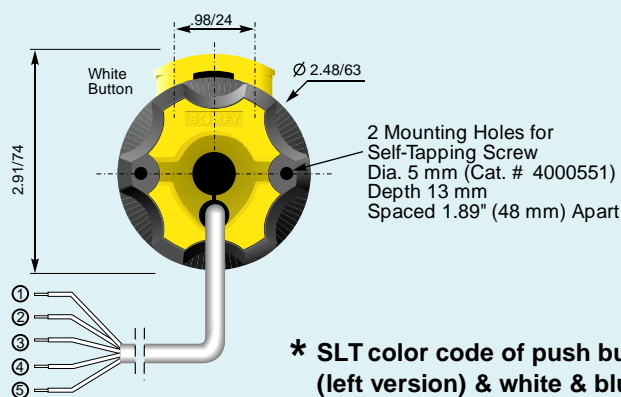

WIRING COLOR CODE FOR LT50/60		
①	White	Neutral
②	Black	White Button
③	Red	Yellow Button
④	Green	Ground
Do Not Wire in Parallel		

WIRING COLOR CODE FOR FTS 50/60		
①	White	Neutral
②	Black	White Button
③	Red	Yellow Button
④	Green	Ground
⑤	Grey	Brake
Do Not Wire in Parallel		

* SLT color code of push buttons is: blue & yellow (left version) & white & blue (right version).

NOTE: Dimensions in millimeters are more accurate. **X** dimension refers to the length of the motor tube and drive assembly. **Y** dimension refers to the distance for mounting the pop rivets.



Dimensions

SOMFY LT50/LT60 CMO, LT50 RH, LT50 ILT RH and LT50 ILT

LT50 CMO

MOTOR TYPE	X in. / mm	Y in. / mm
525A2 CMO	23.39/594	22.80/579
530R2 CMO	23.39/594	22.80/579
535A2 CMO	26.14/664	25.55/649
540R2 CMO	26.14/664	25.55/649
550R2 CMO	26.14/664	25.55/649

LT60 CMO

MOTOR TYPE	X in. / mm	Y in. / mm
660R2 CMO	25.4/646	24.8/630
680R2 CMO	26.8/681	26.2/665
6100R2 CMO	26.8/681	26.2/665

NOTE 1:
 LT50 Tube Diameter = 1.85"/47 mm
 LT60 Tube Diameter = 2.36"/60 mm

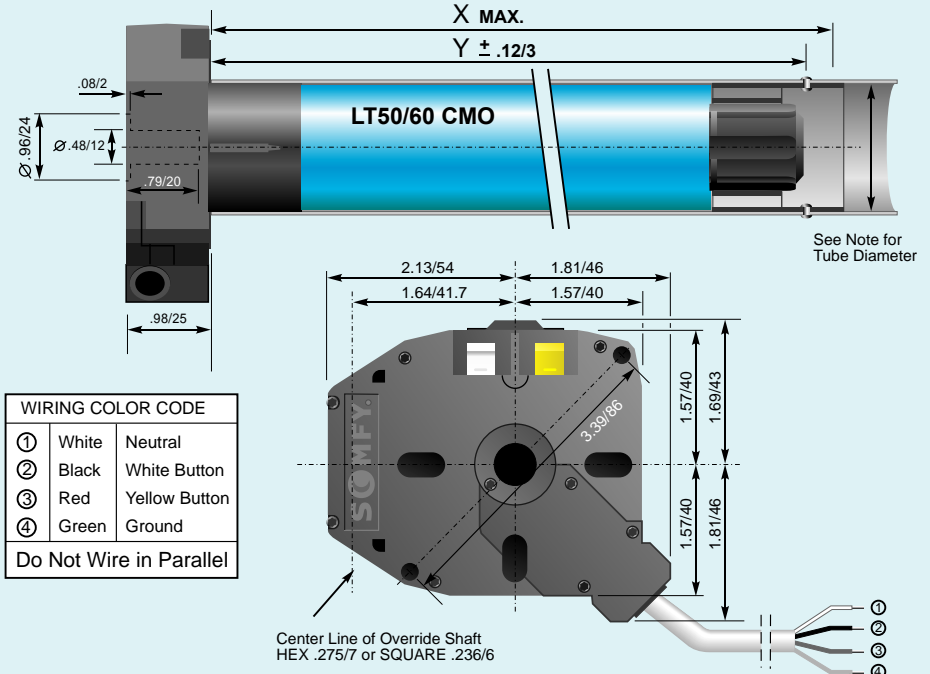

LT50 RH

MOTOR TYPE	X in. / mm	Y in. / mm
504S2 RH	19.9/505	19.3/490
506S2 RH	20.7/525	20.1/510
510S2 RH	21.9/555	21.3/540
515S2 RH	23.8/605	23.2/590
520R2 RH	20.7/525	20.1/510

2 Mounting Holes for Self-Tapping Screw
 Dia. 4 mm (Cat. # 4000555)
 Depth 9 mm, Spaced 1.14" (29 mm) Apart

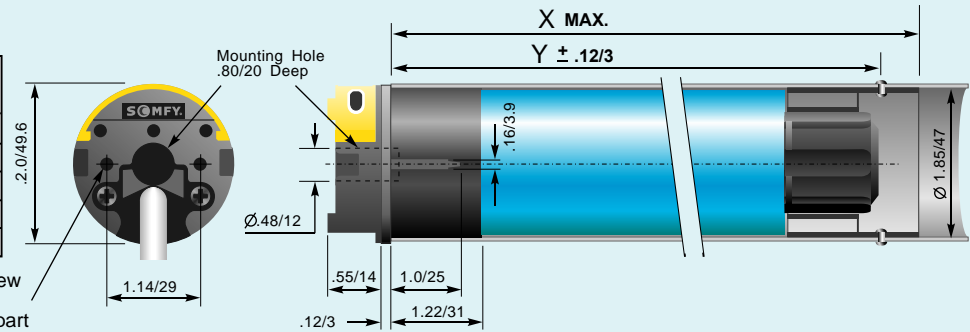

LT50 ILT RH

MOTOR TYPE	X in. / mm	Y in. / mm
506S2 ILT RH	23.8/605	23.2/590
515S2 ILT RH	26.6/675	26.0/660
535A2 ILT RH	26.6/675	26.0/660

Standard ILT*

MOTOR TYPE	X in. / mm	Y in. / mm
506S2 ILT	23.8/605	23.2/590
515S2 ILT	26.6/675	26.0/660
535A2 ILT	26.6/675	26.0/660

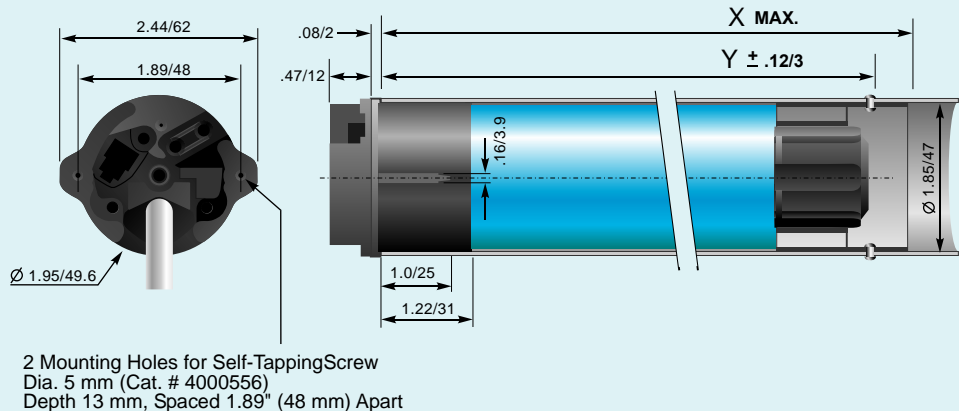

* NOTE: Refer to page 10 (LT50 Dimensions) for the standard ILT starhead dimensions.

NOTE: Dimensions in millimeters are more accurate. X dimension refers to the length of the motor tube and drive assembly. Y dimension refers to the distance from mounting the pop rivets.



Dimensions

SOMFY LT50 ALTUS RTS, LT50 OREA RTS and LT50 RTS CMO

LT50 ALTUS RTS

MOTOR TYPE	X in. / mm	Y in. / mm
506S2 ALTUS RTS	23.82/605	23.23/590
510S2 ALTUS RTS	25.79/655	25.20/640
525A2 ALTUS RTS	25.79/655	25.20/640
530R2 ALTUS RTS	25.79/655	25.20/640
535A2 ALTUS RTS	26.57/675	25.98/660
540R2 ALTUS RTS	26.57/675	25.98/660
550R2 ALTUS RTS	26.57/675	25.98/660

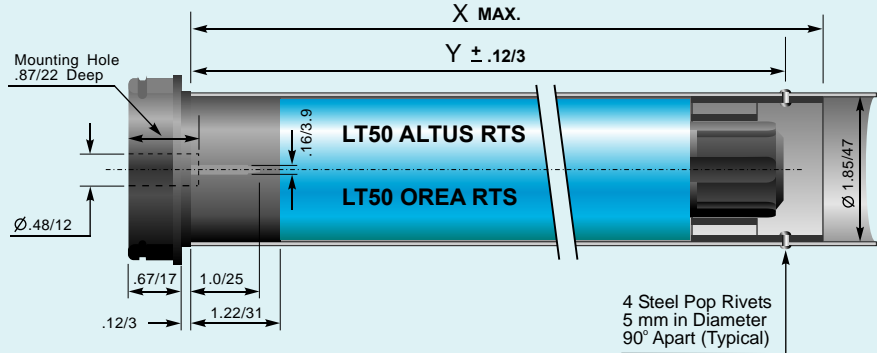

LT50 OREA RTS

MOTOR TYPE	X in. / mm	Y in. / mm
535A2 OREA RTS	26.6/675	26.0/660
550R2 OREA RTS	26.6/675	26.0/660

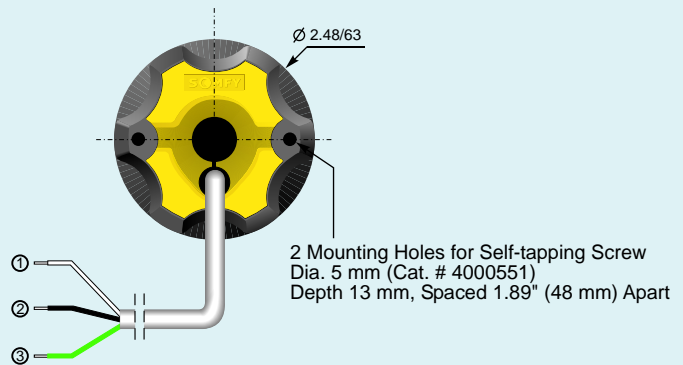

LT50 RTS CMO

MOTOR TYPE	X in. / mm	Y in. / mm
525A2 RTS CMO	30.47/774	29.88/759
530R2 RTS CMO	30.47/774	29.88/759
535A2 RTS CMO	30.47/774	29.88/759
540R2 RTS CMO	30.47/774	29.88/759
550R2 RTS CMO	30.47/774	29.88/759

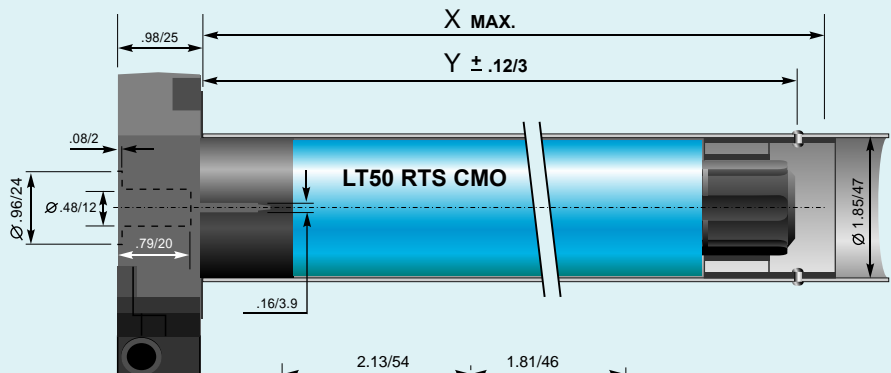

WIRING COLOR CODE FOR RTS MOTORS		
①	White	Neutral
②	Black	Hot
③	Green	Ground
Can be Wired in Parallel		

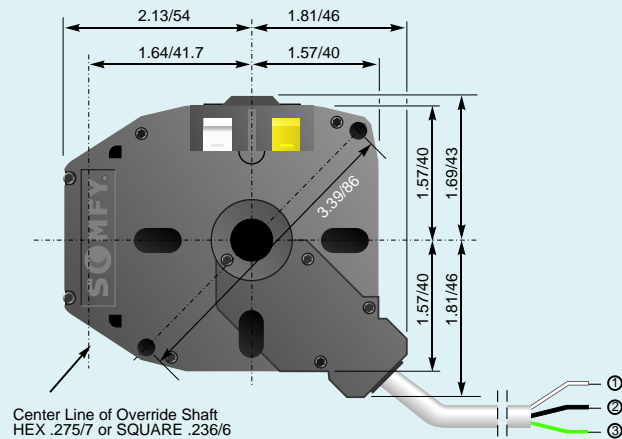

NOTE: Dimensions in millimeters are more accurate. **X** dimension refers to the length of the motor tube and drive assembly. **Y** dimension refers to the distance for mounting the pop rivets.



The Concept of Torque

Whatever the application, a specific torque (lifting capacity) will be required to motorize the operation. The speed at which the application will then operate depends on the designated speed (RPM) of the motor.

Therefore, the main criteria for motor selection is torque. The following selector charts are based on the torques each of the motors will produce for various applications under different parameters.

Torque is literally described as the “rotary force within a mechanism”. **More technically:** the product of a force and its perpendicular distance from a point about which it causes rotation or torsion.

$$\text{Torque} = \text{Load} \times \text{Radius}$$

Example: A 1 pound weight hanging from a rope turning around a 1 inch radius roller tube tends to rotate the tube as indicated by the arrow. (see figure 1). This weight generates a torque equal to 1 in. lb. By definition: if the same weight is hanging on a 2 inch radius, the torque applied to the tube is equivalent to 2 in. lbs. (see figure 2). Therefore, the torque generated by the same weight doubles when the tube radius doubles. There is a direct relation between torque and roller tube radius as shown in figures 1 & 2.

FIGURE 1

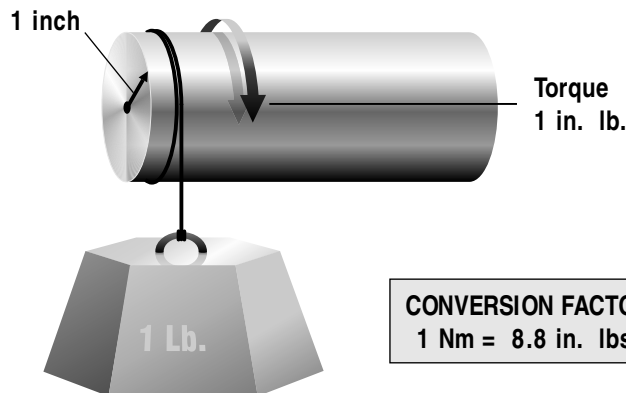
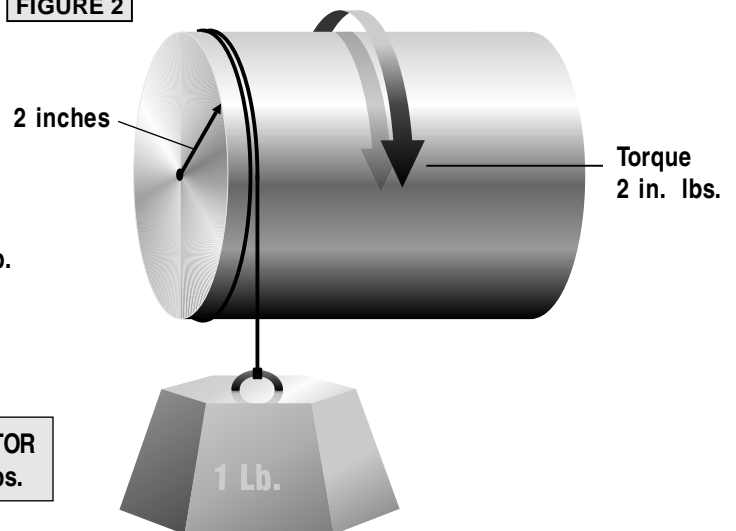

FIGURE 2



CONVERSION FACTOR
1 Nm = 8.8 in. lbs.

Definition of Theoretical Lifting Capacity

The theoretical lifting capacity is an indicator of the torque capability of the motor. However, the actual load values will differ depending on many factors including tube diameter, tube length, material, friction and type of accessories used. Under no circumstances shall the maximum load including all accessories (including the tube) in the system (between the 2 motor brackets) exceed the **maximum load rating of system's individual components.**

For all LS40 motors the theoretical lifting capacity is given on a 40 mm (1.57") tube. Length and tube deflection will determine its load capacity.

For all LT50 motors theoretical lifting capacity is given on a 2" tube. Length and tube's deflection will determine its load capacity.

For all LT60 motors theoretical lifting capacity is given on a 2.5" tube. Length and tube's deflection will determine its load capacity.

Please contact SOMFY Systems, Inc. with questions pertaining to maximum load requirements.



Motor Selection Guide For Retractable Awning Systems

		1 Pair (2 arms)	2 Pair (4 arms)	3 Pair (6 arms)	4 Pair (8 arms)	5 Pair (10 arms)	6 Pair (12 arms)
		20 ft. (6 m)	33 ft. (10 m)	50 ft. (15 m)	66 ft. (20 m)	82 ft. (25 m)	100 ft. (30 m)
A	D						
Projection of Arms	Roller Tube O.D. Sizes						
5 ft. (1.5 m)	2.5" (63)	525A2		535A2	550R2	660R2	
	3.0" (78)	535A2		550R2	660R2		680R2
	3.5" (89)	535A2	550R2	660R2	680R2		
6.5 ft. (2.0 m)	2.5" (63)	525A2	535A2	540R2	660R2	680R2	6100R2
	3.0" (78)	535A2	540R2	550R2	660R2	680R2	
	3.5" (89)	540R2	550R2	660R2	680R2		
8 ft. (2.4 m)	2.5" (63)	535A2	550R2		660R2		6100R2
	3.0" (78)	550R2		660R2		680R2	
	3.5" (89)	550R2	660R2	680R2			
9 ft. (2.7 m)	2.5" (63)	540R2	550R2	660R2	680R2		
	3.0" (78)	550R2	660R2	680R2	6100R2		
	3.5" (89)	550R2	660R2	680R2	6100R2		
10 ft. (3.0 m)	2.5" (63)	540R2	550R2	680R2			
	3.0" (78)	550R2	680R2		6100R2		
	3.5" (89)	660R2	680R2	6100R2			
13.5 ft. (4.0 m)	2.5" (63)	550R2	680R2	6100R2			
	3.0" (78)	680R2	6100R2				
16.5 ft. (5.0 m)	2.5" (63)	550R2	680R2				
	3.0" (78)	680R2	6100R2				

Above chart is approximate.
For more specific information,
refer to factory.

NOTE: The Selection Guidelines pertaining to the **CMO RTS** and **Altus RTS** motors are the same as above.

This chart can be used to select the most suitable type of motor for your lateral arm awning system.
Important: The lateral arms referred to here are the standard aluminum type with built-in tension springs. When considering arms made of steel and/or using other types of spring mechanisms, please request additional information.

1. Locate the projection of your lateral arm on the above chart at point (A); e.g. 5 ft., 6 ft., 8 ft., etc.
2. Determine which roller tube diameter (D) is being used in your installation.

3. Locate the number of arms (B) and the length of your installation (C).
4. Read the correct motor from the chart at the intersection of your selections.

NOTE:

Because this chart must take into consideration lateral arms being manufactured by many different companies, it is only approximate. The relationship between the number of arms and the length of the awning is only a guide and will vary slightly from manufacturer to manufacturer.



Motor Selection Guide

For Rolling Shutters

To select a motor in this guide you need to know the following:

1. Type of slat: Height and Thickness
2. Total weight of shutter
3. Diameter of the tube



Type of Slat:

It is important to consider the height and thickness of the slats before choosing an operator, since these variables affect the weight per square foot of a rolling shutter. In the next four pages you will find four types of slats. Choose the one that most closely corresponds to the slat that you intend to use.

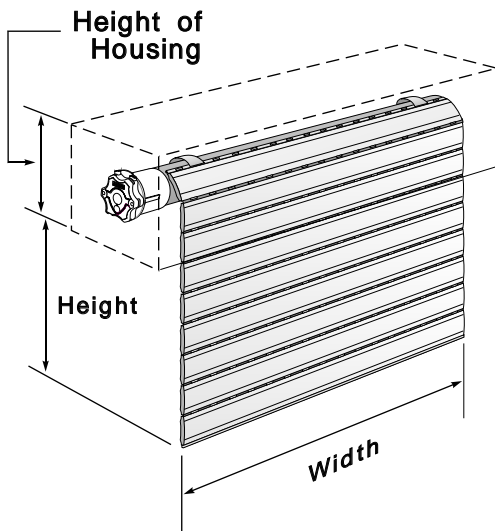

Total Weight of Shutter

$$\text{Total weight} = \underbrace{\text{Width} \times (\text{Height} + \text{Height of Housing})}_{\text{surface}} \times \text{Weight per sq. ft.}$$

Important Note:

The choice of a motor also depends on the type of installation.

- If you use one motor for two or more shutters add 15% for each additional shutter to derive the total weight.

Examples: 2 shutters/one motor = + 15% to the total weight

3 shutters/one motor = + 30% to the total weight

- If the roller tube is too far from the tracks, add 15% to the total weight

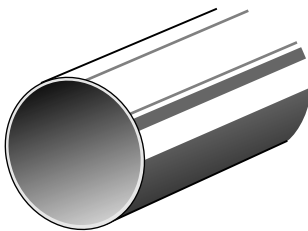

Diameter of Tube:

The lifting capacity of an operator decreases when the tube diameter increases. Therefore, it is necessary to choose the smallest tube while considering the load capacity of the tube and the optimum roll-up diameter of the slats.

After choosing the roller tube and the chart corresponding to your type of slat (see pages 17-20), select the operator according to the weight and the total height of the shutter (the safety factor is included in these charts).

TORQUE REQUIREMENT DIAGRAM

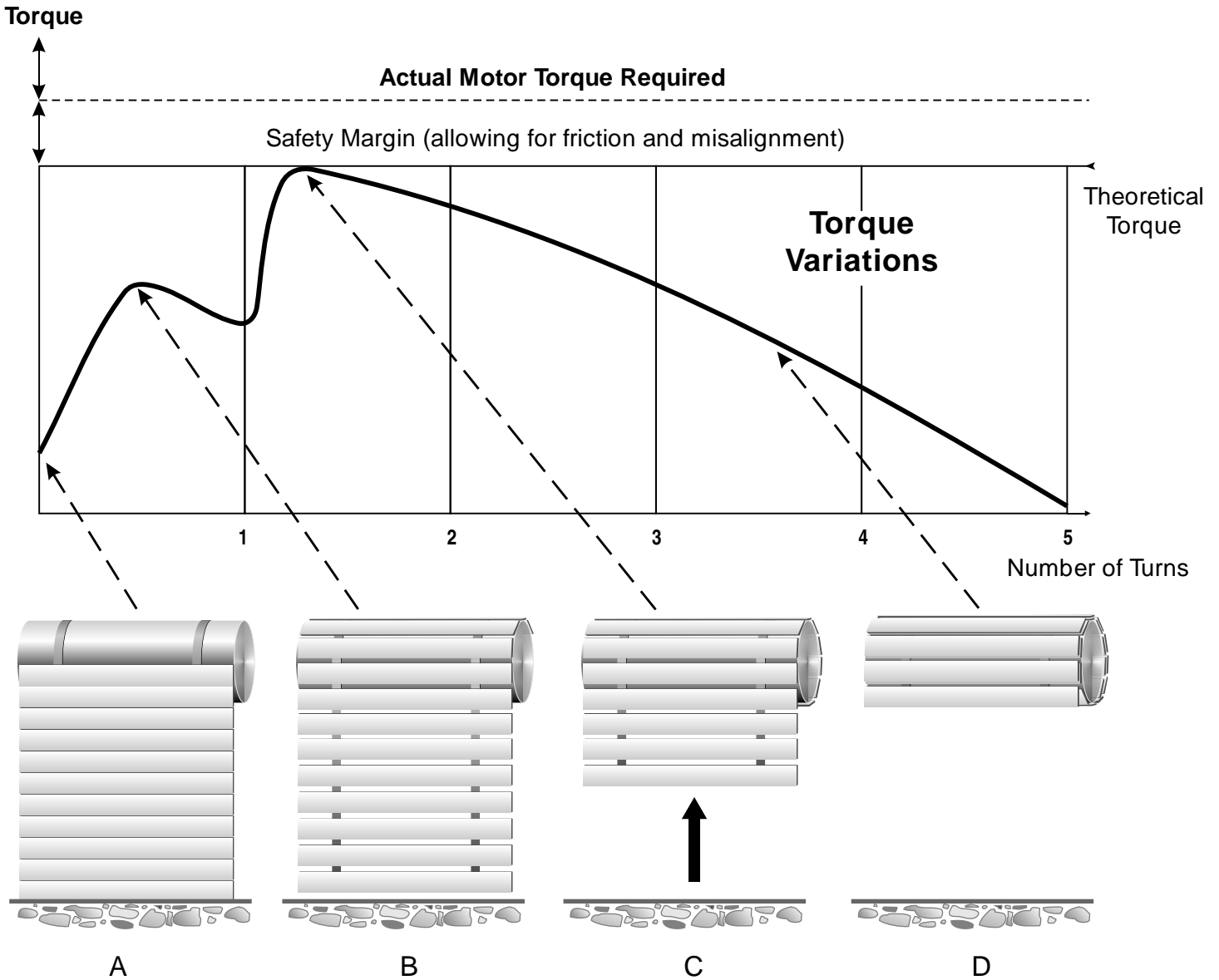

A. The initial torque required to start lifting the slats is small. However, it increases rapidly. This results from the motor lifting the load of the slats away from the bottom of the application.

B. All slats are hanging free. The torque may slightly decrease while the slats are rolling up, since the tube radius has not yet increased.

C. The maximum torque required is arrived at when the slats are lifted up about one third of the way from the bottom of the application.

D. The torque decreases progressively and reaches a minimum when the shutter is fully rolled up.



Motor Selection Guide For Rolling Shutters

After choosing the roller tube and the page corresponding to your type of slat, select the operator according to the weight and the total height of the shutter (A safety factor is included in these charts).

TYPE OF SLAT: HEIGHT 1.44" TO 1.50" (36/38 mm) THICKNESS .340" TO .355" (9 mm)

HEIGHT: 0 TO 5 FT.

TYPE OF TUBE	kg.	9	18	27	36	45	55	64	73	82	91	100	109	118	127	136	145	155	164	173
	lb.	20	40	60	80	100	120	140	160	180	200	220	240	260	280	300	320	340	360	380
OCTA. 40																				
ROUND 2.5" (63.5)																				
OCTA. 60 Round 70																				
OCTA. 70 Round 75																				
ROUND 3.5" (89)																				

HEIGHT: 5 FT. TO LESS THAN 8 FT.

TYPE OF TUBE	kg.	9	18	27	36	45	55	64	73	82	91	100	109	118	127	136	145	155	164	173
	lb.	20	40	60	80	100	120	140	160	180	200	220	240	260	280	300	320	340	360	380
OCTA. 40																				
ROUND 2.5" (63.5)																				
OCTA. 60 Round 70																				
OCTA. 70 Round 75																				
ROUND 3.5" (89)																				

HEIGHT: 8 FT. TO 11.5 FT.

TYPE OF TUBE	kg.	9	18	27	36	45	55	64	73	82	91	100	109	118	127	136	145	155	164	173
	lb.	20	40	60	80	100	120	140	160	180	200	220	240	260	280	300	320	340	360	380
OCTA. 40																				
ROUND 2.5" (63.5)																				
OCTA. 60 Round 70																				
OCTA. 70 Round 75																				
ROUND 3.5" (89)																				



Motor Selection Guide For Rolling Shutters

TYPE OF SLAT: HEIGHT 1.58" TO 1.65" (40/42 mm) THICKNESS .340" TO .355" (9 mm)

HEIGHT: 0 TO 5 FT.

TYPE OF TUBE	kg.	9	18	27	36	45	55	64	73	82	91	100	109	118	127	136	145	155	164	173	
	lb.	20	40	60	80	100	120	140	160	180	200	220	240	260	280	300	320	340	360	380	
ROUND 2.5" (63.5)																					
OCTA. 60 Round 70																					
OCTA. 70 Round 75																					
ROUND 3.5" (89)																					

HEIGHT: 5 FT. TO LESS THAN 8 FT.

TYPE OF TUBE	kg.	9	18	27	36	45	55	64	73	82	91	100	109	118	127	136	145	155	164	173	
	lb.	20	40	60	80	100	120	140	160	180	200	220	240	260	280	300	320	340	360	380	
ROUND 2.5" (63.5)																					
OCTA. 60 Round 70																					
OCTA. 70 Round 75																					
ROUND 3.5" (89)																					

HEIGHT: 8 FT. TO 11.5 FT.

TYPE OF TUBE	kg.	9	18	27	36	45	55	64	73	82	91	100	109	118	127	136	145	155	164	173	
	lb.	20	40	60	80	100	120	140	160	180	200	220	240	260	280	300	320	340	360	380	
ROUND 2.5" (63.5)																					
OCTA. 60 Round 70																					
OCTA. 70 Round 75																					
ROUND 3.5" (89)																					



Motor Selection Guide For Rolling Shutters

TYPE OF SLAT: HEIGHT 1.986" TO 2.10" (50/53 mm) THICKNESS .55" (14 mm)

HEIGHT: 0 TO 5 FT.

TYPE OF TUBE	kg.	9	18	27	36	45	55	64	73	82	91	100	109	118	127	136	145	155	164	173	
	lb.	20	40	60	80	100	120	140	160	180	200	220	240	260	280	300	320	340	360	380	
ROUND 2.5" (63.5)		510R2	520R2	530R2	540R2	550R2															
OCTA. 60 Round 70		510R2	520R2	530R2	540R2	550R2															
OCTA. 70 Round 75		510R2	520R2	530R2	540R2	550R2															
ROUND 3.5" (89)		510R2	520R2	530R2	540R2	550R2															

HEIGHT: 5 FT. TO LESS THAN 8 FT.

TYPE OF TUBE	kg.	9	18	27	36	45	55	64	73	82	91	100	109	118	127	136	145	155	164	173	
	lb.	20	40	60	80	100	120	140	160	180	200	220	240	260	280	300	320	340	360	380	
ROUND 2.5" (63.5)		510R2	520R2	530R2	540R2	550R2	660R2	680R2	6100R2												
OCTA. 60 Round 70		510R2	520R2	530R2	540R2	550R2	660R2	680R2	6100R2												
OCTA. 70 Round 75		510R2	520R2	530R2	540R2	550R2	660R2	680R2	6100R2												
ROUND 3.5" (89)		510R2	520R2	530R2	540R2	550R2	660R2	680R2	6100R2												

HEIGHT: 8 FT. TO 11.5 FT.

TYPE OF TUBE	kg.	9	18	27	36	45	55	64	73	82	91	100	109	118	127	136	145	155	164	173	
	lb.	20	40	60	80	100	120	140	160	180	200	220	240	260	280	300	320	340	360	380	
ROUND 2.5" (63.5)		510R2	520R2	530R2	540R2	550R2	660R2	680R2	6100R2												
OCTA. 60 Round 70		510R2	520R2	530R2	540R2	550R2	660R2	680R2	6100R2												
OCTA. 70 Round 75		510R2	520R2	530R2	540R2	550R2	660R2	680R2	6100R2												
ROUND 3.5" (89)		510R2	520R2	530R2	540R2	550R2	660R2	680R2	6100R2												



Motor Selection Guide For Rolling Shutters

TYPE OF SLAT: HEIGHT 2.125" TO 2.20" (54/56 mm) THICKNESS .55" (14 mm)

HEIGHT: 0 to 5 FT.

TYPE OF TUBE	kg.	9	18	27	36	45	55	64	73	82	91	100	109	118	127	136	145	155	164	173	
	lb.	20	40	60	80	100	120	140	160	180	200	220	240	260	280	300	320	340	360	380	
OCTA. 60 Round 70			510R2	520R2	530R2	540R2	550R2														
OCTA. 70 Round 75			510R2	520R2	530R2	540R2	550R2														
ROUND 3.5" (89)			510R2	520R2	530R2	540R2	550R2														

HEIGHT: 5 FT. TO LESS THAN 8 FT.

TYPE OF TUBE	kg.	9	18	27	36	45	55	64	73	82	91	100	109	118	127	136	145	155	164	173	
	lb.	20	40	60	80	100	120	140	160	180	200	220	240	260	280	300	320	340	360	380	
OCTA. 60 Round 70			510R2	520R2	530R2	540R2	550R2	660R2	680R2												
OCTA. 70 Round 75			510R2	520R2	530R2	540R2	550R2	660R2	680R2												
ROUND 3.5" (89)			510R2	520R2	530R2	540R2	550R2	660R2	680R2												

HEIGHT: 8 FT. TO 11.5 FT.

TYPE OF TUBE	kg.	9	18	27	36	45	55	64	73	82	91	100	109	118	127	136	145	155	164	173	
	lb.	20	40	60	80	100	120	140	160	180	200	220	240	260	280	300	320	340	360	380	
OCTA. 60 Round 70			510R2	520R2	530R2	540R2	550R2	660R2	680R2												
OCTA. 70 Round 75			510R2	520R2	530R2	540R2	550R2	660R2	680R2												
ROUND 3.5" (89)			510R2	520R2	530R2	540R2	550R2	660R2	680R2												



Motor Selection Guide For Window Coverings (Roll-up Applications)

LT28 MOTOR SELECTION CHART

TYPE OF TUBE	kg.	9	18	27	36
	lb.	20	40	60	80
ROUND 29 mm		LT28			

LS40 MOTOR SELECTION CHART

TYPE OF TUBE	kg.	9	18	27	36
	lb.	20	40	60	80
ROUND 40 mm		401F2	404S2	OTHER LS40 RANGE MOTORS	
ROUND 2.0" (50.8)		401F2	404S2	OTHER LS40 OR LT50 RANGE MOTORS	
ROUND 2.5" (63.5)		401F2	404S2	OTHER LS40 OR LT50 RANGE MOTORS	

LT50 AND LT50 RTS MOTOR SELECTION CHART

TYPE OF TUBE	kg.	9	18	27	36	45	55	64	73	82
	lb.	20	40	60	80	100	120	140	160	180
ROUND 2.0" (51)		504S2	506S2	510S2	515S2	OTHER LT50 RANGE MOTORS				
ROUND 2.5" (63.5)		504S2	506S2	510S2	515S2	OTHER LT50 RANGE MOTORS				
ROUND 3.0" (76)		504S2	506S2	510S2	515S2	OTHER LT50 RANGE MOTORS				
ROUND 3.5" (89)		504S2	506S2	510S2	515S2	OTHER LT50 RANGE MOTORS				





Motor Selection Guide

For Interior Window Coverings

PLEATED, CELLULAR AND ROMAN

Motor Type	Output Drive (Hexagonal Shaft)	Maximum area for Pleated Shades Sq. Ft.	Maximum area for Cellular Shades Sq. Ft.	Roman Shades Lbs.	Maximum height with 1.4 mm cord	Speed (RPM)
LV 25-B44	Single	60 Sq. Ft.	53 Sq. Ft.	4.25 Lbs.	11.5 Ft.	40
LV 25-B64	Single	90 Sq. Ft.	75 Sq. Ft.	7.5 Lbs.	11.5 Ft.	35
LW 25-B44	Double	60 Sq. Ft.	53 Sq. Ft.	4.25 Lbs.	11.5 Ft.	40
LW 25-B83	Double	120 Sq. Ft.	105 Sq. Ft.	8.5 Lbs.	11.5 Ft.	30

Specifications based on motors used with (CTS). They are approximate and may vary depending on product application, fabric etc.

Motor Type	Output Drive	Maximum area for Pleated Shades Sq. Ft.	Maximum area for Cellular Shades Sq. Ft.	Roman Shades Lbs.	Maximum height with 1.4 mm cord	Speed (RPM)
LT28	Tubular	120 Sq. Ft.	105 Sq. Ft.	8.8 Lbs.	13 Ft.	34
LS40*	Tubular	> 120 Sq. Ft.	> 105 Sq. Ft.	21 Lbs.	18 Ft.	36
LT50**	Tubular	> 120 Sq. Ft.	> 105 Sq. Ft.	42 Lbs.	19.8 Ft.	38

Specifications based on motors used with (CTS). They are approximate and may vary depending on product application, fabric etc.

* LS40 Based on use of 404S2
** LT50 Based on use of 510S2

HORIZONTAL BLINDS

Motor Type	Output Drive (Hexagonal Shaft)	Maximum area for 25 mm Aluminum blinds (Sq. Ft.)	Maximum area for 50 mm Wood blinds (Sq. Ft.)	Maximum height with Ø 1.4 mm cord (Ft.)	Speed (RPM)
LV 25-B44	Single	22 Sq. Ft.	NA	11.5 Ft.	40
LV 25-B64	Single	44 Sq. Ft.	NA	11.5 Ft.	35
LV 25-B44	Double	22 Sq. Ft.	NA	11.5 Ft.	40
LV 25-B83	Double	54 Sq. Ft.	27 Sq. Ft.	11.5 Ft.	30

Specifications based on motors used with (CTS). They are approximate and may vary depending on product application.

Motor Type	Output Drive	Maximum area for 25 mm Aluminum blinds (Sq. Ft.)	Maximum area for 50 mm Wood blinds (Sq. Ft.)	Maximum height with Ø 1.4 mm cord (Ft.)	Speed (RPM)
LS40*	Tubular	75 Sq. Ft.	75 Sq. Ft.	13 Ft.	16
LT50**	Tubular	75 Sq. Ft.	120 Sq. Ft.	19.8 Ft.	14

Specifications based on motors used with (CTS). They are approximate and may vary depending on product application.

* LS40 Based on use of 409R2
** LT50 Based on use of 510R2

ILT Motor

The ILT motor features an on board microprocessor and uses a digital shaft encoder to track the position of the motor. Limits are set using the ILT switch itself, virtually eliminating the need to access the motor when adjusting the limits. A low voltage modular cable links the motor to the switch, and a separate 3-conductor (L-N-G) cable supplies power to the motor.

On-board control and electronic limits are combined to provide these additional features:

- * Low voltage control from a switch, infrared transmitter, home automation or network controls
- * Individual or group control from a switch or IR sensor without additional components
- * One user defined intermediate stop from a switch or remote

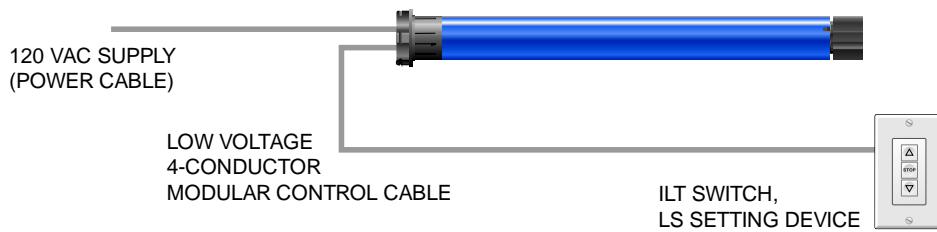

Alternative Configurations

GROUP CONTROL

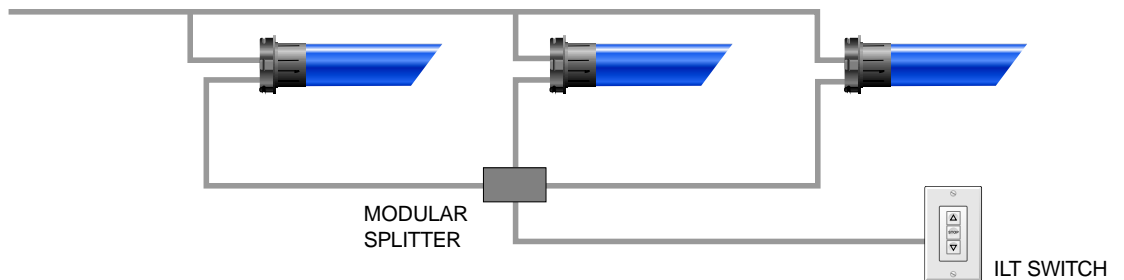

IR REMOTE Individual

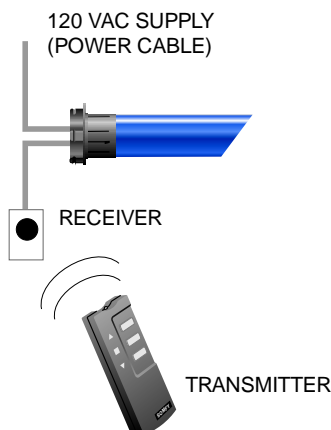

Group Control

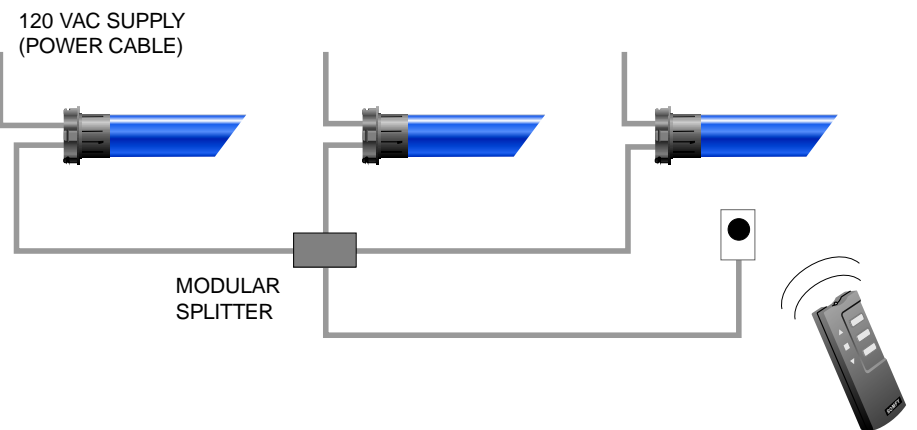

FTS - Fabric Tension System

The FTS is a specialized system designed for the solar protection market where horizontal or inclined type shading is required. This system was designed for fabric and shading material. SOMFY has tested the FTS Control for rolling shutters and does not recommend it.

The system consists of two specific motors, an electronic control unit and a switch. One motor is inserted into the fabric roll-up tube and is referred to as the fabric motor. The other is inserted into the strap take-up tube and is called the strap motor. While not every application will have a load bar and straps as below, these references will help reduce confusion during installation.

The electronic control unit operates each motor independently and maintains a desirable dynamic (moving) tension as well as final tension in the system, eliminating fabric sag while the fabric is both moving and standing. Adjustment to both dynamic and final tension can be made through the electronic control.

Never Leave the dynamic and final tension at 0. This setting is only used during initial FTS installation. It is strongly recommended that both the dynamic and final tension be set to a minimum value of 5.

All mechanical accessories of the FTS System and the mounting method must be capable of withstanding the tension and forces exerted by the motors.

For the **525A2 FTS** motor, the entire FTS system must be able to withstand a minimum of **250 Lbs. of force**. This value was obtained based on both the fabric tube and strap tube having a **diameter of 2.5"**.

For the **655A2 FTS** motor, the entire FTS system must be able to withstand a minimum of **500 Lbs. of force**. This value was based on both the fabric tube and strap tube having a **diameter of 3.5"**.

NOTE: The SOMFY FTS System is a specialized system and should not be installed without proper training from a SOMFY technician.

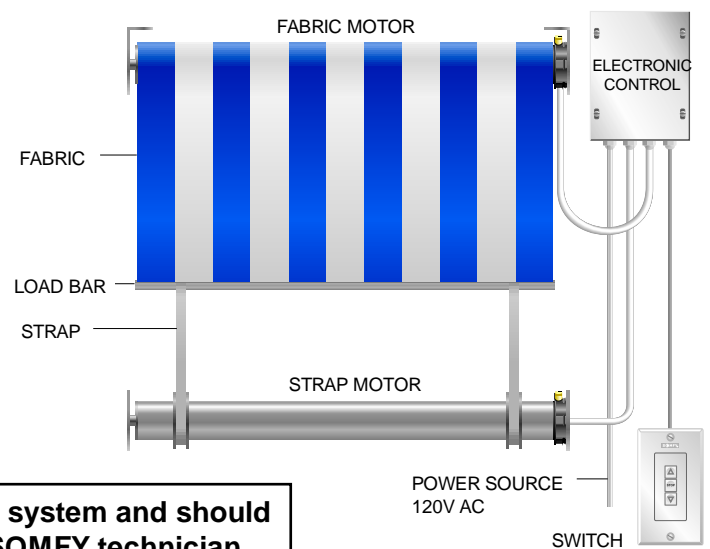

For a quick reference guide to our installations, refer to page 26 and 27 of this catalog. The complete instructions are available on our website at www.somfysystems.com under the **Technical Documentation** section.

SLT and OREA RTS Motors

SLT

The SLT Range is made exclusively for cassette awnings. What separates the SLT from a standard LT is the on-board control which detects when a cassette is almost closed and reduces the torque of the motor for the last few inches of travel. Then when the headrail meets the cassette, the on-board control shuts the motor off. The combination of digital control plus a reduced-torque closing provides the maximum protection against fabric stretch. For more information, turn to page 66.

OREA RTS

The new radio version of the SLT motor is the OREA RTS. This motor can be mounted on the left or right side of the cassette awning and is compatible with the RTS sensors. It features an integrated radio receiver with remote limit setting and a remote user programmable intermediate stop.



FTS Motor Selection Guide

This motor chart was created based on experimental results. The following tube diameters were used:

	FABRIC TUBE	STRAP TUBE
LT50	Ø70	Ø63
LT60	Ø78	Ø63

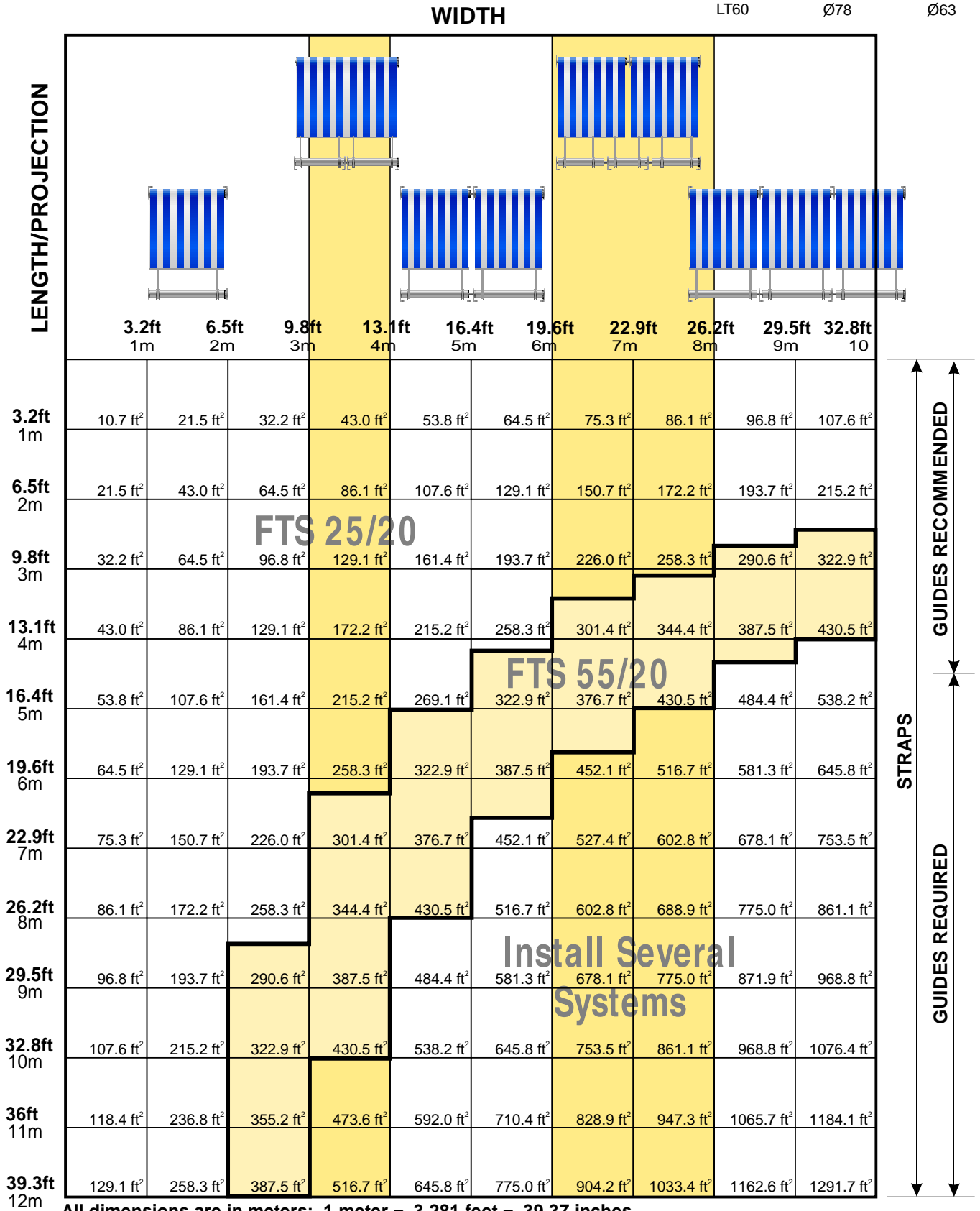

All dimensions are in meters: 1 meter = 3.281 feet = 39.37 inches.

A. INSTALLATION PROCEDURE

Using the SOMFY FTS selector chart (located on page 25 of this catalog or our website) select the appropriate sized motors. Operators should then be fit into their respective tubes in accordance with standard installation instructions, using the correct crown and drive. All mechanical accessories of the system and the mounting method must be capable of withstanding the tension and forces exerted by the motors (please refer to page 24 for these values).

Before proceeding, press in both limits on each motor, and leave the buttons locked in the "in" position.

Rotation Directions

The illustrations at right represent a view of the motors (Fabric and Strap Motor) looking at the head with the push buttons at the 12 o'clock position. The concept illustrated here applies for all LT FTS configurations. The white push button always corresponds to the black motor wire and the yellow push button always corresponds to the red motor wire. Only the "Winding Direction" and "Tension Direction" designation change depending on whether the fabric or straps are winding on the motor tube "Winding Direction" or unwinding from the tube "Tension Direction". It is crucial that you identify the proper motor configuration of your installation in the chart on the following page and use the wiring chart below it to later connect to the appropriate terminals of the FTS control.

The motorized tubes should be mounted onto their respective brackets. **The locking stop ring included with each operator MUST be used with the motor end bracket.** Ensure that the motorized tubes are parallel and fabric is rolled up. Attach Straps to the strap tube. Connect the Tester cable to the motor leads as shown in the table to the right, and in fig. 2 below. The winding direction will have the power switched, and the tension direction is not used.

FABRIC MOTOR	Tester Cable	STRAP MOTOR
Fabric Winding	Black	(not connected)
Gray	Gray	Gray
Green	Green	Green
White	White	White
(not connected)	Red	Strap Winding

Setting the Limits for the first time

Both limits must be set on each motor. Use the Limit Setting chart below to determine the order in which the limits are set for a given motor and fabric orientation.

1. Unwind the fabric using the tester cable (fig. 2). When the desired position is reached, set the strap tube limit by pressing and releasing the PRIMARY limit (1) on the strap motor tube. Then press and release the SECONDARY limit (2) on the fabric motor.
2. Using the tester cable, wind the fabric around the fabric tube (fig. 3). When the desired position is reached, press and release the PRIMARY limit (3) on the fabric motor tube. Then press and release the SECONDARY limit (4) on the strap motor.
3. Before connecting the motors to the controller, run the system (using the tester cable) in both directions to verify that the system works correctly.

NOTE: If any limits need to be readjusted, be sure to re-set both the primary and secondary limits for the system in the correct order as described above.

Limit Setting Order According to Motor Configuration

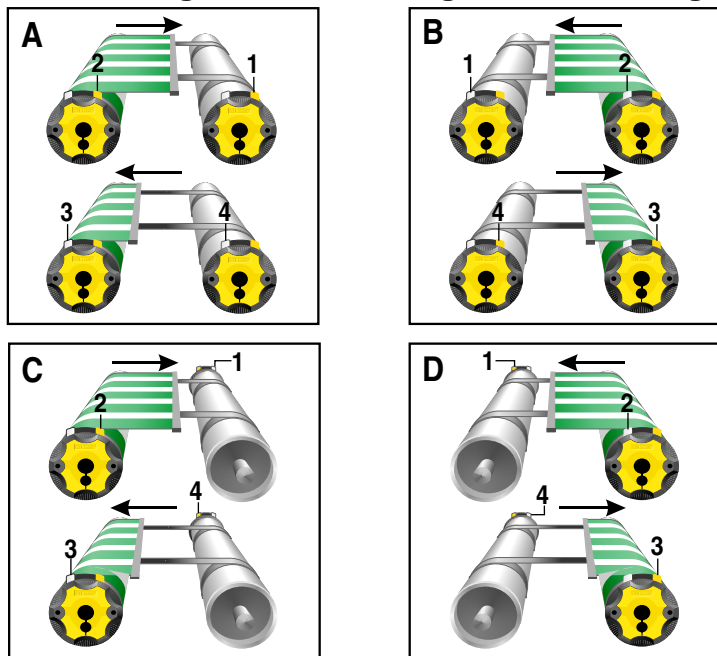

Fig. 1

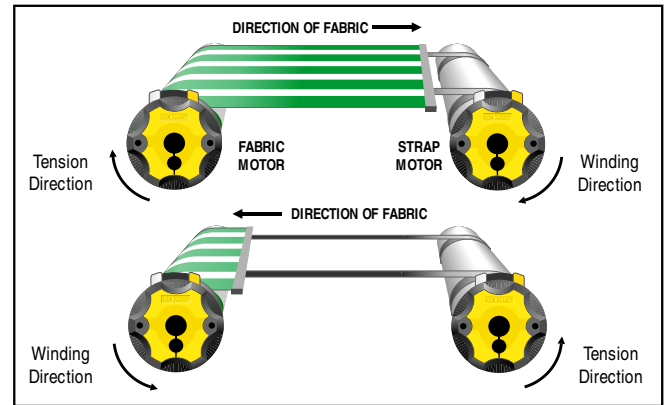

Fig. 2

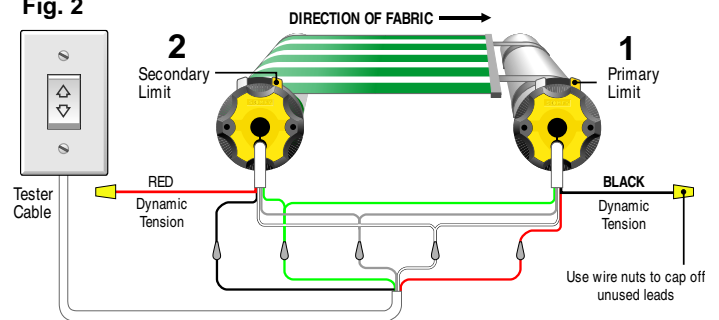
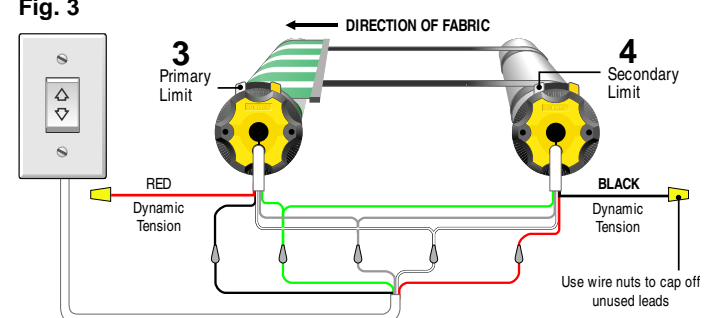

Fig. 3



B. INSTALLATION CONFIGURATIONS

Below are the Four Motor Configurations that are possible with the FTS System:

The different configurations each require a unique instruction for wiring and limit setting.

Wiring Identification

The tables below the illustrations describe the wiring scheme with FTS control terminal identification based on the motor and fabric orientation above it.

NOTE: The illustration on top is configured exactly the same as the one below it, only flipped over to visually illustrate the fabric rolling above or below the tube.

A

WIRING	TERMINAL #
FABRIC MOTOR	
White	3 Common
Black	7 Winding
Red	8 Tension
Gray	9 Brake
Green	* Ground
STRAP MOTOR	
White	3 Common
Red	4 Winding
Black	5 Tension
Gray	6 Brake
Green	* Ground

* USE GROUND BAR

B

WIRING	TERMINAL #
FABRIC MOTOR	
White	3 Common
Red	7 Winding
Black	8 Tension
Gray	9 Brake
Green	* Ground
STRAP MOTOR	
White	3 Common
Black	4 Winding
Red	5 Tension
Gray	6 Brake
Green	* Ground

* USE GROUND BAR

C

WIRING	TERMINAL #
FABRIC MOTOR	
White	3 Common
Black	7 Winding
Red	8 Tension
Gray	9 Brake
Green	* Ground
STRAP MOTOR	
White	3 Common
Black	4 Winding
Red	5 Tension
Gray	6 Brake
Green	* Ground

* USE GROUND BAR

D

WIRING	TERMINAL #
FABRIC MOTOR	
White	3 Common
Red	7 Winding
Black	8 Tension
Gray	9 Brake
Green	* Ground
STRAP MOTOR	
White	3 Common
Red	4 Winding
Black	5 Tension
Gray	6 Brake
Green	* Ground

* USE GROUND BAR

C. FINAL CONNECTIONS

All wiring must conform to NEC (National Electrical Code) and local codes.

Before connecting the operators to the electronic control, set the tension adjustment potentiometers to "0" and ensure that all the dip switches are in the "off" position.

Referring to charts above, connect the motors and switch to the electronic control as shown in the diagram to the right.

Check that the system operates correctly with respect to the switch directions. Make sure the limits have been properly set. At this point, there may be some fabric sag - this is normal.

To finish the installation, set both the dynamic and final tension adjustment potentiometers to a minimum value of 5. This will remove all the fabric sag in the system and ensure proper operation of the FTS installation.

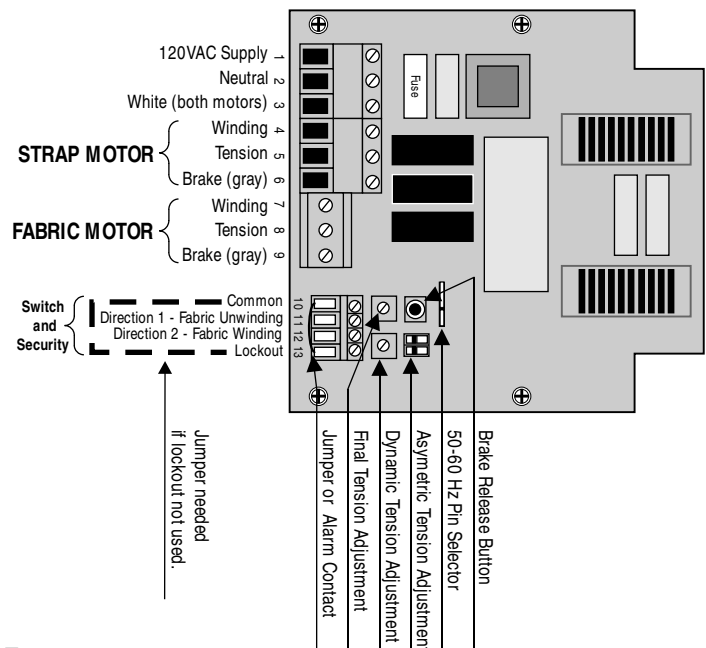



DC Motor Mechanical Accessories











DC LT28 BRACKETS AND END CAPS



Dimensions (mm)	Cat. Number	Description
	6180353	Angle Brackets w/Teflon Bushings - 4 screws and anchors included - Ø 4 mm idler bushing included
	6180354	Angle Brackets w/Plastic Caps - Compatible with 6090315 idler end cap - Pin Ø 4 mm
	6180356	Standard Brackets
	6090315	End Cap For Tube 28 x 0.7 mm, 29 x 1.15 mm and 29 x 2.0 mm - Pin Ø 4 mm
	6061298	Flush Mount Bracket for LT28A and LT28B Motor



DC Motor Mechanical Accessories







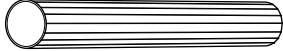
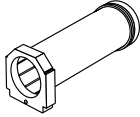
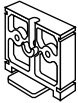

Headrail Adaptors for LV and LW Motors

Dimensions (mm)	Cat. Number	Description
	6050009	Headrail Adaptor for 25 x 25 mm/Celebrity/Best Buy
	6050008	Headrail Adaptor for Fbr. 25 x 25 mm
	6050007	Headrail Adaptor for SoftLine®
	6050006	Headrail Adaptor for MidiMatic®
	6050005	Headrail Adaptor for Classic Supreme®
	6050004	Headrail Adaptor for Verosol Europe/Mexico
	6050010	Headrail Adaptor for VersaRail/Easy Up/Activator/EasyGlide®
	6050650	Headrail Adaptor for EasyRise® (New Version/Old Version)
	6050600	Headrail Adaptor for GutterRail/Low Profile 2" Headrail
	6050602	Headrail Adaptor for SureClose® Headrail
	6050013	Headrail Adaptor for LightLines®

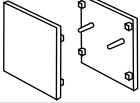
Dimensions (mm)	Cat. Number	Description
	6050003	Shaft Adaptor for 5 mm Hexagonal
	6051003	Long Shaft Adaptor for 5 mm Hexagonal
	6050002	Shaft Adaptor for 5 mm Square
	6050001	Shaft Adaptor for 6 mm Hexagonal
	6051001	Long Shaft Adaptor for 6 mm Hexagonal
	6050000	Adjustable Mechanical Stop (AMS)
	6050666	Wall Mount Brackets for RDS/RTS Control
	6050403	Ladder Braid Crimps

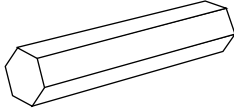

DC Motor Mechanical Accessories

Dimensions (mm)	Cat. Number	Description
	6050026	29 mm Round Tube (Max. 16 ft.)
	6050029	NEW 29 mm Tube w/"Grooved" Surface (Max. 20 ft.)
	6180029	NEW CTS29 w/New Molded Cradle Assembly Kit
	6070029	NEW Molded LT28 Motor/Idler Brackets
	6050129	NEW 45 x 51 mm Extruded Aluminum White Headrail (Max. 20 ft.)
	6080029	NEW Headrail Mounting Brackets
	6050290	NEW Headrail Side Caps
	6090315	End Cap for 29 mm Tube
	6050411	Decorative Tape Adaptors for (1") Cotton Tape
	6050412	Decorative Tape Adaptors for (1.5") Cotton Tape
	6050406 6050505	5 mm Hex Shaft for CTS (16 Ft. Maximum Length) 6 mm Hex Shaft for CTS (6 Ft. Sections)
	6050400	Stop Collar Ring for 5 mm Hex Shaft
	6050401	Stop Collar Ring for 6 mm Hex Shaft

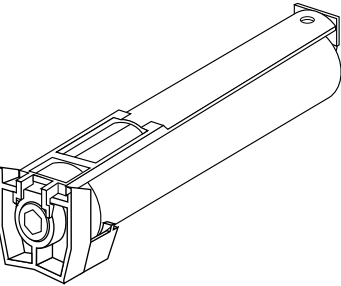
Dimensions (mm)	Cat. Number	Description
	6180367	29 mm Cone and Ring (Kit)
	6180029	CTS 29 mm for SOMFY 46 x 51 mm Headrail
	6180389	CTS 25 (Kit) for Standard 1" x 1" Headrail (5 mm Hex Shaft)
	6180393	CTS 25 (Kit) for Standard 1" x 1" Headrail (5 mm Sq Shaft)
	6180395	CTS 25 (Kit) for Standard 1" x 1" Headrail (6 mm Hex Shaft)
	6180396	CTS 25 (Kit) for Classic Supreme® Headrail (5 mm Hex Shaft)
	6180394	CTS 25 (Kit) for Classic Supreme® Headrail (6 mm Hex Shaft)
	6180397	CTS 25 (Kit) for VersaRail/Easy-Up/EasyGlide® (5 mm Hex Shaft)
	6180398	CTS 25 (Kit) for VersaRail/Easy-Up/EasyGlide® (6 mm Hex Shaft)
	6180407	CTS 25 (Kit) for LightLines® (5 mm Hex Shaft)
	6180408	CTS 25 (Kit) for LightLines® (6 mm Hex Shaft)
	6180404	CTS 25 (Kit) for GutterRail/Low Profile 2" Headrail (5 mm Hex Shaft)
	6180405	CTS 25 (Kit) for GutterRail/Low Profile 2" Headrail (6 mm Hex Shaft)
	6180600	CTS 25 (Kit) for EasyRise® (New Version) Headrail (5 mm Hex Shaft)
	6180601	CTS 25 (Kit) for EasyRise® (New Version) Headrail (6 mm Hex Shaft)
	6180497	CTS 25 (Kit) Short Cones for VersaRail Headrail (5 mm Hex Shaft)
	6180498	CTS 25 (Kit) Short Cones for VersaRail Headrail (6 mm Hex Shaft)

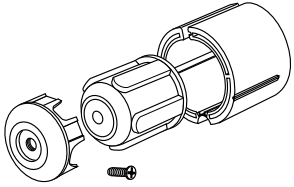
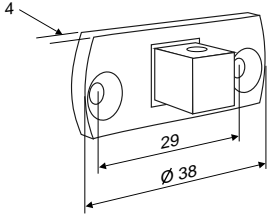
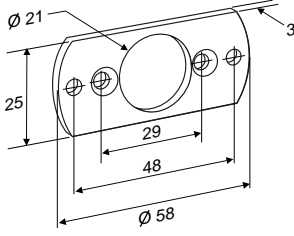
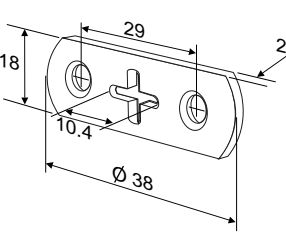
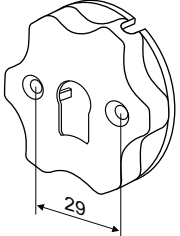
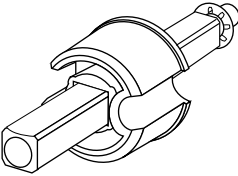
Dimensions (mm)	Cat. Number	Description
	6061308	<p>LS40 to LT50 Adaptor Kit</p> <ul style="list-style-type: none"> - Allows the use of LT50 crowns and drives with LS40 motors - Black composite - Maximum motor torque - 13 Nm - Maximum system load - 56 Kg (123 Lbs.)
	6070418	<p>LS40 "LO" Bracket with a Square Stud</p> <ul style="list-style-type: none"> - Motor mounting screws included - 10 mm square stud - Zinc plated steel - Maximum motor torque - 13 Nm - Maximum system load - See note below
	6070521	<p>LS40 and LT50 RH "LO" Bracket with Round Hole</p> <ul style="list-style-type: none"> - Two motor mounting screws included - Zinc plated steel - Maximum motor torque - 20 Nm - 2 holes for 1/4-20 screws on 48 mm diameter - Maximum system load - 70Kg (154 Lbs.) - Replaces SOMFY Cat. No. 6070419
	6070427	<p>LS40 Motor Bracket</p> <ul style="list-style-type: none"> - Compatible with Rollease™ Bracket - Stainless steel - Maximum motor torque - 4 Nm - Maximum system load - See note below
	6070429	<p>LS40 to LT50 Mounting Conversion Bracket</p> <ul style="list-style-type: none"> - Black composite - Allows LS40 motors to be used with LT motor brackets - Maximum motor torque - 9Nm - 2 screws included - Maximum system load - 56 Kg. (123 Lbs.)
	6090307	<p>40 mm Diameter Adjustable End Cap</p> <ul style="list-style-type: none"> - 12 mm dia. shaft (Zinc plated steel) - Cast aluminum with set screw...set screw must use lock-tight to prevent screw from vibrating free. - Kit containing (6090310, 6090195). These parts are available separately. - Maximum system load - See note below

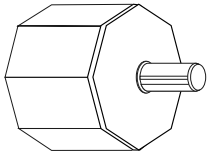
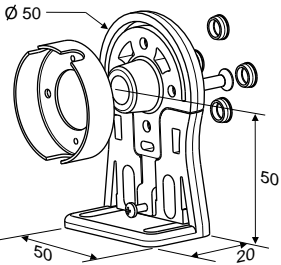
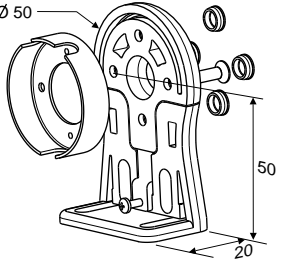
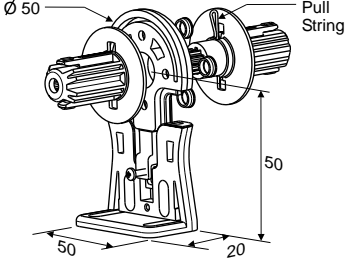
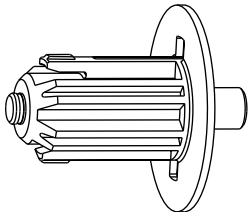
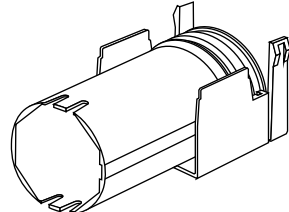

Note: Maximum system load will vary depending on application. SOMFY recommends testing of component in actual application to determine its suitability.

Dimensions (mm)	Cat. Number	Description
	6090185	40 x 0.6 mm Octagonal Tube End Cap - 8 mm dia. shaft - White composite - Maximum system load - See note below
	6090186	40 x 1.1 mm Octagonal Tube End Cap - Same as above but modified to fit 40 x 1.1 mm tube
	6080040	LS40 Idler Bracket (for 8 mm shaft) - Decorative white composite - Maximum motor torque - 4Nm (removable parts must be screwed together, see enclosed instructions). - Maximum system load - 17 Kg. (38 Lbs.)(must be screwed together) - Compatible with motor bracket Cat. # 6070040
	6070040	LS40 Radial Square Motor Bracket - Decorative white composite - Maximum motor torque - 4Nm (removable parts must be screwed together, see enclosed instructions) - Maximum system load - 17 Kg. (38 Lbs.)(must be screwed together) - Compatible with idler bracket 6080040
	6050040	LS40 Intermediate Bracket - Decorative white composite - Maximum motor torque - 4Nm (removable parts must be screwed together, see enclosed instructions). - Maximum system load - 17 Kg. (38 Lbs.)(must be screwed together) - Any LS40 drive wheel may be used to adapt to any tube profile - Pull string used to disengage intermediate connection
	6090040	LS40 Idler End Cap with 8 mm Diameter Pin - Decorative white composite - Maximum motor torque - 13Nm - Any LS40 drive wheel may be used to adapt to any tube profile - Maximum system load - See note below
	6180391	CTS 40 Kit for GutterRail 2" x 2 1/4" Headrail

Note: Maximum system load will vary depending on application. SOMFY recommends testing of component in actual application to determine its suitability.



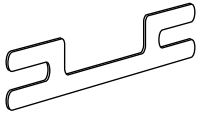

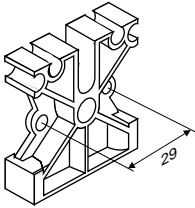

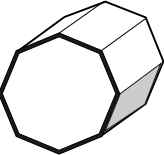

LS40 Mechanical Accessories

Dimensions (mm)	Cat. Number	Description
	6050521	40 mm Octagonal Tube (Sold in 20 ft. lengths)
	6050408 6050409 6050410	2" Slat Clips for Wood Blinds (White) 2" Slat Clips for Wood Blinds (Ivory) 2" Slat Clips for Wood Blinds (Brown)
	6050089	40 mm Fabric Clip
	6080251	LS40 Motor/Idler Bracket for 2" x 2 1/4" GutterRail Headrail - requires 2 screws (4000555 not included)

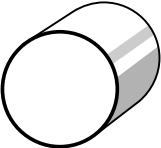

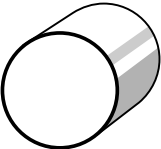
Crowns and Drives

Dimensions (mm)	Cat. Number	Description
 	6061287	LS40 Crown for 40 x 0.8 mm Octagonal Tube
	6061289	LS40 40 mm Octagonal Set
	6061286	LS40 Drive for 40 x 0.8 mm Octagonal Tube
 	6061285	LS40 Crown for (40 x 1.5 mm) Tube
	6061288	LS40 40 mm Round Set
	6061284	LS40 Drive for (40 x 1.5 mm) Tube
 	6061310	LS40 Crown for (40 x 1.0 mm) Tube
	6061309	LS40 Drive for (40 x 1.0 mm) Tube





LT50/60 Mechanical Accessories

Motor Brackets

Dimensions (mm)	Cat. Number	Description
	6070003	<p>LT50 Motor Angle Bracket</p> <ul style="list-style-type: none"> - Zinc-plated steel - .807 in. diameter through hole - Maximum motor torque - 40 Nm - Compatible with 9080239 idler end bearing support - Maximum system load - See note below
	6070082	<p>Universal LT50 Motor Bracket (LS Style) for 10 mm Square Stud</p> <ul style="list-style-type: none"> - Zinc-plated steel - Maximum motor torque - 25 Nm - Horizontally and vertically adjustable - Maximum system load - 57 Kg. (126 Lbs.) - Replaces SOMFY Cat. No. 6070081
	6070138	<p>"U" Shape LS Style Motor Bracket for 10 mm Square Stud</p> <ul style="list-style-type: none"> - Maximum motor torque - 25 Nm - Zinc-plated steel - Maximum system load - See note below - Replaces SOMFY Cat. No. 6070137
	6070182	<p>Heavy Duty Angle Plate</p> <ul style="list-style-type: none"> - For ceiling and wall installation in combination with Cat. No. 6070503 - Black oxide finish - Compatible with brackets 6070503, 6080026 and 6080116 - Maximum motor torque - 100 Nm - Maximum system load - See note below
	6070238	<p>LT50 Round Anti-Vibration Motor Bracket</p> <ul style="list-style-type: none"> - Zinc plated steel with a 10 mm molded square stud insert surrounded by rubber - Compatible with matching idler end Cat. # 6080206 - Can be mounted on 6070526 - Maximum motor torque - 20Nm - Can reduce sound levels by 4-5 dB - Maximum system load - See note below
	6070256	<p>Motor Bracket LT60 FTS</p> <ul style="list-style-type: none"> - Zinc plated steel, gauge 3 (0.24 in.) - Recommended for use with LT FTS 60 (Fabric Tension System) - Maximum motor torque - 100 Nm - Includes universal bracket with spring ring that must be used - Maximum system load - 200 kg. (441 Lbs.) - Spring must be replaced with a locking spring ring 4350027 to obtain full torque and load capability.

Note: Maximum system load will vary depending on application. SOMFY recommends testing of component in actual application to determine its suitability.



LT50/60 Mechanical Accessories

Motor Brackets

Dimensions (mm)	Cat. Number	Description
	6070284	<p>LT50 Angle Plate with Elongated Holes Allowing Adjustment</p> <ul style="list-style-type: none"> - Zinc plated steel - Compatible with idler end bearing support Cat. No. 9080239 and intermediate bearing support Cat. No. 6050438 - Maximum motor torque - 50 Nm - Maximum system load - 69 Kg. (152 Lbs.) - Replaces SOMFY Cat. No. 6070283
	6070446	<p>LT50/60 Motor Bracket with 1/2" Conduit Connector</p> <ul style="list-style-type: none"> - Four mounting holes provided - Lateral space requirement for installation: 28 mm - Zinc plated steel - Must be used with either spring ring Cat. No. 4350026, or locking spring ring Cat. No. 4350027 (not included) - Maximum motor torque - 85 Nm or 100 Nm when locking spring ring Cat. # 4350027 is used.
	6070499	<p>Universal Bracket with Spring Ring</p> <ul style="list-style-type: none"> - Assembled to accept Inch Series threaded screws 1/4 - 20, 5/16 - 18 (nuts molded into bracket)
	6070501	<p>Universal Bracket with Spring Ring - Zamak Material</p> <ul style="list-style-type: none"> - 2 holes for M6 hex or 1/4 - 20 flat head screw on 48 mm diameter - 2 holes for M8 hex screw on 60 mm diameter - 2 countersunk holes for M8 screw on 60 mm diameter - Lateral space requirement for installation: 27 mm - Maximum motor torque - 85 Nm or 100 Nm when used with locking spring ring Cat. No. 4350027, and 5/16 - 18 or M8 bolts without molded nuts - Maximum system load - 200 Kg. (441 Lbs.) when used with locking spring ring Cat. # 4350027
<p>Spring ring needs to be replaced with locking spring ring Cat. # 4350027 to obtain maximum torque and load capability</p>	6070502	<p>With M8 and M6 nuts molded in bracket</p> <ul style="list-style-type: none"> - Same as above - Maximum system load 200 Kg. (441 Lbs.)
	6070500	<p>Weld-on Bracket Without Spring Ring</p> <ul style="list-style-type: none"> - Steel bracket without surface treatment - For welding to mounting plates of all kinds. Lateral space requirement for installation: 23 mm + thickness of mounting plate - Must be used with spring ring Cat. No. 4350026 or locking spring ring Cat. No. 4350027 (not included) - Maximum motor torque - 85 Nm or 100 Nm depending on spring ring and quality of weld - Maximum system load - 200 Kg. (441 Lbs.) when used with locking spring ring Cat. # 4350027



LT50/60 Mechanical Accessories

Motor Brackets

Dimensions (mm)	Cat. Number	Description
	<p>6070504</p> <p>6070506</p>	<p>Heavy Duty Angle Plate with Universal Motor Bracket</p> <ul style="list-style-type: none"> - With two M8 screws and nuts included - Angle plate (zinc-plated steel) - Three adjustment positions possible - Maximum motor torque - 85 Nm or 100 Nm when used with locking spring ring Cat. # 4350027 - Maximum system load - 130 Kg. (287 Lbs.) or 200 Kg. (441 Lbs.) when used with locking spring ring Cat. # 4350027 <p>Heavy Duty Angle Plate</p> <ul style="list-style-type: none"> - Same as above but without the universal motor bracket
	6070507	<p>Motor Bracket With Spring Ring (120 mm x 120 mm)</p> <ul style="list-style-type: none"> - Four mounting holes provided - Zinc-plated steel - Lateral space requirement for installation: 28 mm - Maximum motor torque - 85 Nm - Maximum system load - See note below
	6070510	<p>Motor Bracket With Spring Ring (100 mm x 100 mm)</p> <ul style="list-style-type: none"> - Four mounting holes provided with a through hole in the center of the bracket - Zinc-plated steel - Lateral space requirement for installation: 28 mm - Maximum motor torque - 85 Nm - Maximum system load - See note below

Note: Maximum system load will vary depending on application. SOMFY recommends testing of component in actual application to determine its suitability.





LT50/60 Mechanical Accessories

Motor Brackets

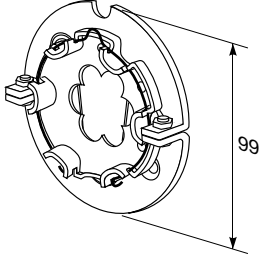
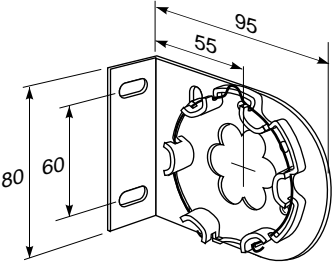
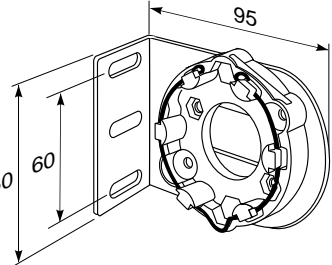
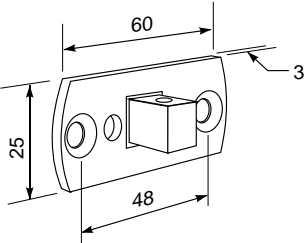
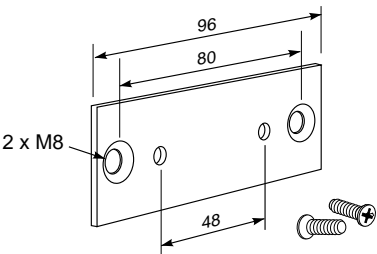
Dimensions (mm)	Cat. Number	Description
	6070511	<p>LT50/60 Radial Motor Bracket</p> <ul style="list-style-type: none"> - Maximum motor torque 80 Nm - Zinc plated steel - Allows for easy removal of LT motor without removing entire bracket. It disassembles in 2 pieces with one part remaining attached to structure - Maximum system load - See note below
	6070513	<p>LT50 Universal Motor Bracket</p> <ul style="list-style-type: none"> - Maximum motor torque - 50 Nm - Zinc plated steel - Maximum system load - 115 Kg. (254 Lbs.)
	6070509	<p>LT50 Adjustable Universal Motor Bracket</p> <ul style="list-style-type: none"> - Zinc plated steel - Without molded nuts - Maximum motor torque - 50 Nm - Maximum system load - 115 Kg. (254 Lbs.) - Replaces SOMFY Cat. No. 6070514
	6070515	<p>Retrofit Brackets</p> <ul style="list-style-type: none"> - Zinc plated steel - yellow - LO LT motor bracket with a 10 mm stud. Vertical pin hole - Mounting screws Cat. No. 4000551 not included - Maximum motor torque - 25 Nm for new LT applications - 35 Nm for replacing LS motor with LT motor - Maximum system load - 70 Kg. (154 Lbs.)
	6070516	<p>Same as above, except pin hole is horizontal</p>
	6070517	<p>"LO" LT50 Motor Bracket</p> <ul style="list-style-type: none"> - Comes with two 5 mm motor mounting screws - Maximum motor torque 50 Nm - Zinc plated steel - Maximum system load - See note below

Note: Maximum system load will vary depending on application. SOMFY recommends testing of component in actual application to determine its suitability.



LT50/60 Mechanical Accessories

Motor Brackets

Dimensions (mm)	Cat. Number	Description
	6070518	Adjustable Motor Bracket with Spring Ring <ul style="list-style-type: none"> - Zinc-plated steel - Horizontally and Vertically adjustable - Lateral space requirement for installation: 27 mm - Maximum motor torque 50 Nm - Maximum system load - See note below
	6070519	LT50 HA Motor Bracket <ul style="list-style-type: none"> - Allows flush mounting of the motor head against the mounting surface - Zinc plated steel - Maximum motor torque - 50 Nm - Maximum system load - See note below
	6070522	LT RH Motor Bracket <ul style="list-style-type: none"> - Pin hole is vertical - Zinc plated steel - 10 mm square stud - Maximum motor torque - 25 Nm - Mounting Screws Cat. No 4000555 included - Maximum system load - 70 Kg. (154 Lbs.)
	6070523	Same as above except pin hole is horizontal
	6070524	LT60 Retrofit Bracket with Spring Ring <ul style="list-style-type: none"> - Zinc plated steel - Maximum motor torque - 80 Nm - Allows retrofitting new LT60 motor into old 600s brackets - Maximum system load - See note below
	6070525	LT Motor Bracket with a Square 16 x 16 mm Stud <ul style="list-style-type: none"> - Zinc plated steel - Maximum motor torque - 80 Nm - Required spring ring Cat. No. 4350026 not included - Maximum system load - See note below

Note: Maximum system load will vary depending on application. SOMFY recommends testing of component in actual application to determine its suitability.



LT50/60 Mechanical Accessories

Motor Brackets

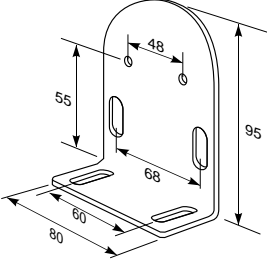
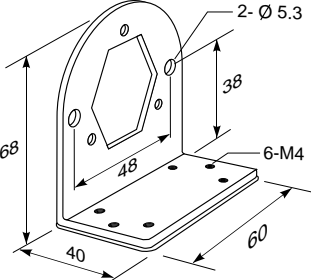
Dimensions (mm)	Cat. Number	Description
	6070526	LT50 Angle Bracket <ul style="list-style-type: none">- For ceiling and wall installation- Zinc plated steel- Horizontally and vertically adjustable- Maximum motor torque - 50Nm- Maximum system load - See note below- Replaces SOMFY Cat. No. 6070193
	6070188	CTS50 Motor Mounting Bracket (Cord Take-Up System) <ul style="list-style-type: none">- Zinc plated steel- Attaches directly to LT50 motor head (48 mm on center)- Adaptable for Nichibeï headrail (70 x 70)- Maximum motor torque - 10Nm- Maximum system load - See note below

Note: Maximum system load will vary depending on application. SOMFY recommends testing of component in actual application to determine its suitability.





LT50/60 Mechanical Accessories

Idler Brackets

Dimensions (mm)	Cat. Number	Description
	6080189	CTS50 Motor Idler Bracket (Cord Take-Up System) <ul style="list-style-type: none"> - Zinc plated - 10 mm square shaft with ball bearings - Adaptable for Nichibei headrail(70 x 70) - Maximum motor torque - 10Nm - Maximum system load - See note below
	6080254	LT Idler End Bracket (inside diameter 10 mm) <ul style="list-style-type: none"> - Zinc plated steel - 10 mm ID Nylon ball bearing - Compatible with motor bracket 6070082 and 6070513 - Maximum motor torque - 50 Nm - Maximum system load 130 Kg. (287 Lbs.)
	6080255	Same as above but with a 12 mm ID Nylon Ball Bearing <ul style="list-style-type: none"> - Replaces Somfy Cat. No. 6080048 - Replaces Somfy Cat. No. 6080228
	6080105 6080138 6080241 6080149	Idler Bracket 10 mm Ball Bearing and Holder Kit Nylon Ball Bearing with 10 mm ID Nylon Ball Bearing with 12 mm ID Ball Bearing Holder <ul style="list-style-type: none"> - Used with Cat. No. 6080138 or 6080241 ball bearings - Zinc plated steel - Maximum motor torque - 50 Nm - Maximum system load - up to 130 Kg. (287 Lbs.)
	6080116	Heavy Duty Idler Bracket <ul style="list-style-type: none"> - Used with end cap having stationary 16 mm diameter shaft (example Cat. No. 6090256) - Cotter pin holding end cap's shaft included - Zinc plated steel - Maximum motor torque - 100 Nm - Maximum system load - See note below
	6080206	LT50 Round Anti-Vibration Idler Bracket <ul style="list-style-type: none"> - Zinc plated steel with a 10 mm round insert surrounded by rubber - Compatible with matching motor bracket Cat. # 6070238 - Can be mounted on 6070526 - Maximum motor torque - 20Nm - Can reduce sound levels by 4-5 dB - maximum system load - See note below
	6080218	LT50 Idler Bracket with 14 mm ID Bearing <ul style="list-style-type: none"> - Zinc plated steel - Adjustable bearing location - Maximum motor torque - 50 Nm - Maximum system load - See note below - Replaces SOMFY Cat. No. 6080217

Note: Maximum system load will vary depending on application. SOMFY recommends testing of component in actual application to determine its suitability.



LT50/60 Mechanical Accessories

Idler Brackets

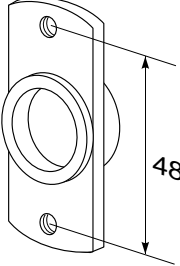
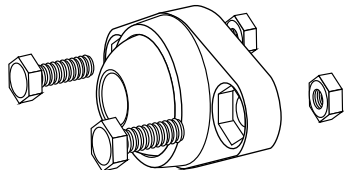
Dimensions (mm)	Cat. Number	Description
	9080239	Idler End Bearing Support for 14 mm Diameter Shaft <ul style="list-style-type: none">- Two threaded mounting holes for M5 screws- Sintered Brass in a zinc plated steel plate- Mounting hardware included- Compatible with shaft (Cat. No.6090207) and brackets (6070003 and 6070283)- Maximum motor torque 50 Nm- Maximum system load - See note below
	6080239	Same as above but hardware not included
	6050438	Idler End Bearing Support for 16 mm Dia. Shaft (no hardware)
	6080250	Idler End 12 mm Nylon Ball Bearing with Holder <ul style="list-style-type: none">- Cast aluminum- Compatible with (bracket Cat. No. 6070506)- Maximum motor torque:<ul style="list-style-type: none">- FTS range - 25 Nm- LT range - 100 Nm- Maximum system load - 130 Kg. (287 Lbs.)

Note: Maximum system load will vary depending on application. SOMFY recommends testing of component in actual application to determine its suitability.



LT50/60 Mechanical Accessories

Idler Brackets

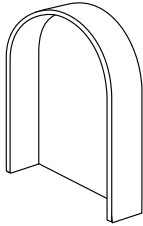
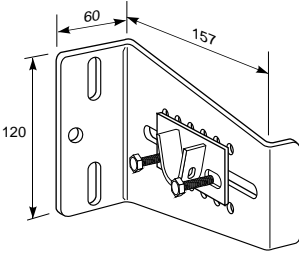
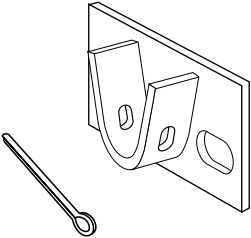
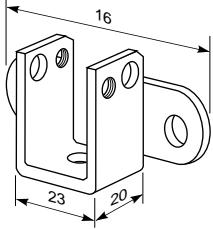
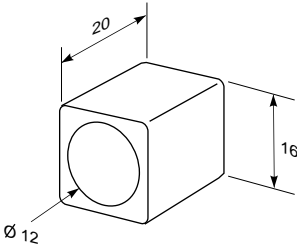
Dimensions (mm)	Cat. Number	Description
	6080262	<p>White Dress Cover for Idler Brackets 6080254, 6080255 and motor brackets 6070082, 6070513 - White composite - Replaces SOMFY Cat. No. 6080252</p>
	6080256	<p>Heavy Duty Idler Bracket with Idler End Cap Holder - Two screws and cotter pin included - Zinc plated steel, gauge 3(0.2391 in.) - Used with end cap having stationary 16 mm diameter shaft - Maximum motor torque when properly installed with cotter pin: - FTS range - 55 Nm - LT range - 100 Nm - Maximum system load - 200 Kg. (441 Lbs.)</p>
	6080257	<p>Idler End Cap Holder - Zinc plated steel - Compatible with bracket (Cat. No. 6070506) - Used with end cap having stationary 16 mm diameter shaft - Maximum motor torque when properly installed with cotter pin: - FTS range - 55 Nm - LT range - 100 Nm - Maximum system load - 200 Kg. (441 Lbs.) - Open end of the "U" must face up</p>
	6080528	<p>"U" Shaped Idler Bracket - Zinc plated steel - Idler bearing securing screw included - Maximum motor torque - 40Nm - Maximum system load - 115 Kg. (254 Lbs.)</p>
	6080529	<p>Idler Bearing (for Ø 12mm Shaft) - Nylon - Maximum motor torque - 40Nm - Compatible with # 6080528 - Maximum system load - 115 Kg. (254 Lbs.)</p>

Note: Maximum system load will vary depending on application. SOMFY recommends testing of component in actual application to determine its suitability.



LT50/60 Mechanical Accessories

Intermediate Brackets

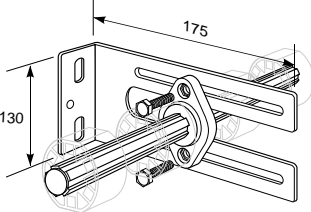
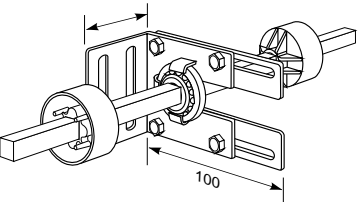
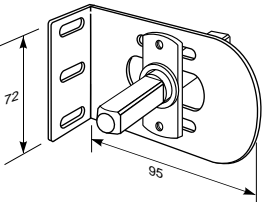
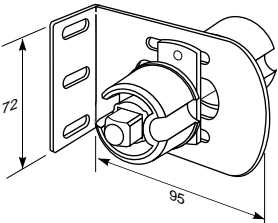
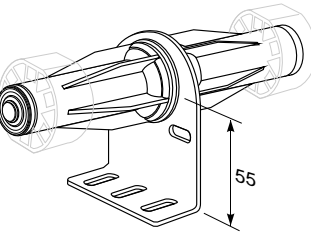
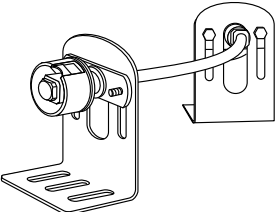
Dimensions (mm)	Cat. Number	Description
	6050256	<p>Heavy Duty LT Intermediate Support Bracket</p> <ul style="list-style-type: none"> - Will adapt to any tube profile using tube matching LT drives - The 4 drives are not included and must be specified separately - Maximum motor torque: <ul style="list-style-type: none"> FTS range - 55 Nm, LT range - 100 Nm - Heavy gauge 3(0.24 in.), zinc plated steel - Extruded aluminum shaft with heavy duty roller bearing - Maximum system load - See note below
	6050269	<p>Light Duty LT50 Intermediate Support Bracket for a 2" Tube</p> <ul style="list-style-type: none"> - Maximum torque - 50 Nm - Zinc plated steel - Adjustable ball bearing location - 2 adjustable cast aluminum drives included along a steel shaft - Maximum system load - See note below
	6050347	<p>LT50 Intermediate Bracket with 16 mm ID Bearing</p> <ul style="list-style-type: none"> - Zinc plated steel - Cat. No. 6050438 16 mm bearing plate also sold separately - Cat. No. 6090252 square shaft also sold separately - Maximum motor torque: <ul style="list-style-type: none"> FTS range - 25Nm, LT50 range - 50Nm - Maximum system load - 69 Kg. (152 Lbs.)
	6050360	<p>LT50 Adjustable Intermediate Support Bracket for a 2" Tube</p> <ul style="list-style-type: none"> - Zinc plated steel bracket - Cast aluminum drives, with set screw - set screw must use lock tight to prevent screw from vibrating free - Maximum motor torque: <ul style="list-style-type: none"> FTS range - 25Nm, LT50 range - 50Nm - Maximum system load - 69 Kg. (152 Lbs.)
	6050371	<p>LT50 Adjustable Intermediate Support Bracket for a 2.5" Tube</p>
	6050530	<p>LT Intermediate Bracket for 2" Tube Only</p> <ul style="list-style-type: none"> - Zinc plated steel bracket - Composite end caps - Maximum motor torque - 15 Nm - Requires properly notched 2" tube for transfer of torque - Recommended tube used included with 2" LT drives - Maximum system load - 69 Kg. (152 Lbs.) - Compatible with LT brackets 6070082, 6080254, and 6080255
	6180451	<p>LT50 Flexible Intermediate Bracket Kit for 2" Tube</p> <ul style="list-style-type: none"> - Maximum angle up to 30° - Maximum effective motor torque - 7 Nm - Zinc plated steel bracket - Cast aluminum drives and flexible coiled steel shaft - Maximum system load - 28 Kg. (60 Lbs.)
	6180452	<p>Same as above except for maximum angle up to 45°</p>

Note: Maximum system load will vary depending on application. SOMFY recommends testing of component in actual application to determine its suitability.



LT50/60 Mechanical Accessories

End Caps

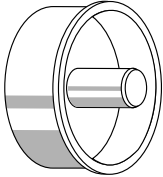
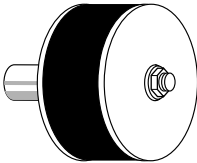
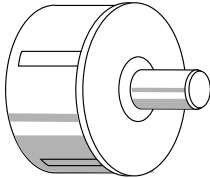
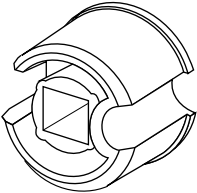
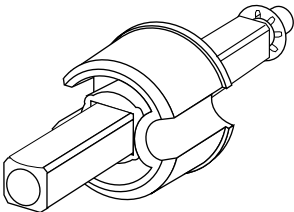
Dimensions (mm)	Cat. Number	Description
	6090005	Die Cast End Cap - For tube diameter 2" (50 mm) - Shaft Diameter 0.39" (10 mm) - Maximum motor torque - 50 Nm - Maximum system load - See note below
	6090285	Same as Above but with 12 mm Shaft
	6090016	2" Anti-Vibration End Cap - For tube diameter 2" (50 x 1.5 mm, 50 x 1.6 mm) - Shaft Diameter 0.39" (10 mm) - Zinc plated steel parts with molded rubber - Maximum system load - See note below
	6090027	Molded Composite End Cap - For tube diameter 2.5" (63 mm) - Shaft Diameter 0.59" (15 mm) - Maximum motor torque - 40 Nm - Maximum system load - See note below
	6090072	- For tube diameter 2.0" (50 mm) - Shaft diameter 0.40" (10 mm) - Maximum motor torque - 50 Nm - Maximum system load - See note below
 <p>NOTE: Set screw must use Lock-tight to prevent screw from vibrating free.</p>	6090162	2" Tube Idler End Cap without Shaft - Cast aluminum with set screw
	6090173	2.5" Tube Idler End Cap without Shaft - Cast aluminum with set screw
	6090184	2.75" Tube Idler End Cap without Shaft - Cast aluminum with set screw
 <p>NOTE: Set screw must use Lock-tight to prevent screw from vibrating free.</p> <p>For maximum system load of these parts - See note below</p>	6090094	2" Tube Adjustable End Cap with 12 mm Diameter Shaft - Kit containing (6090162, 6090195) - Cast aluminum with set screw
	6090139	2" Tube Adjustable End Cap with 14 mm Diameter Shaft - Kit containing (6090162, 6090207) - Cast aluminum with set screw
	6090106	2.5" Tube Adjustable End Cap with 12 mm Diameter Shaft - Kit containing (6090173, 6090195) - Cast aluminum with set screw
	6090140	2.5" Tube Adjustable End Cap with 14 mm Diameter Shaft - Kit containing (6090173, 6090207) - Cast aluminum with set screw
	6090151	2.75" Tube Adjustable End Cap with 14 mm Diameter Shaft - Kit containing (6090184, 6090207) - Cast aluminum with set screw

Note: Maximum system load will vary depending on application. SOMFY recommends testing of component in actual application to determine its suitability.



LT50/60 Mechanical Accessories

End Caps

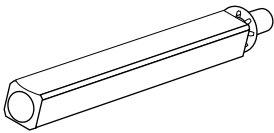
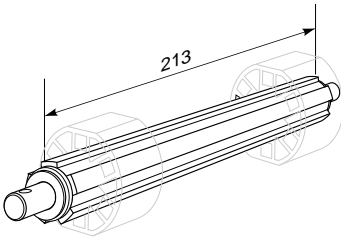
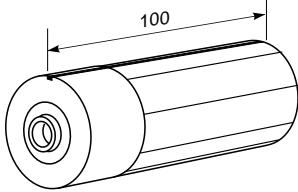
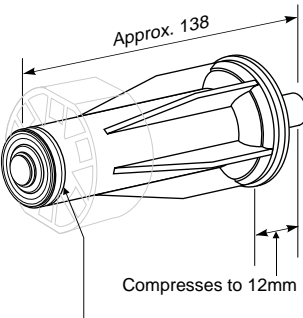
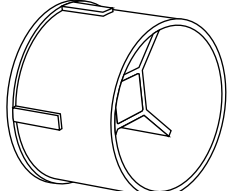



Dimensions (mm)	Cat. Number	Description
	6090195	13 mm Square Drive Shaft with 12 mm Diameter Shaft - Zinc plated steel shaft
	6090207	13 mm Square Drive Shaft with 14 mm Diameter Shaft
	6090256	Heavy Duty End Cap with 16 mm Diameter Shaft - Adaptable to any tube profile using matching LT drives - To be used with Idler bracket accepting stationary shaft Cat. No. 6080257 - Extruded aluminum shaft with heavy duty ball bearings - Maximum motor torque: - FTS range - 55 Nm - LT range - 100 Nm - Maximum system load - 200 Kg. (441 Lbs.)
	6090318	Roller Tube End Cap with 12 mm Hole - For tube 50 x 1.5 mm - Black composite with ball bearing - Maximum system load - See note below
 <p>Retaining Clip #4210017 attaches here</p>	6090323	Universal End Cap for 2" Tube with 10 mm Collapsible Shaft - Requires notched 2" tube and 2" drive (Cat. No. 6061351) held in place with retaining clip included - Black composite - Maximum motor torque: - With awning - 50 Nm - With FTS - 25 Nm - Maximum system load - 40 Kg. (88 Lbs.)
	6090324	Same as above but with 12 mm shaft - Both end caps are adaptable to other tube profiles using LT50 motor crowns and drives. SOMFY recommends using these end caps in conjunction with the LT drive. - Same torque & load rating as above.
	6090325	Same as above but with 14 mm Shaft
	6090190	Idler End Cap for CTS 50 Tube - Maximum system load - See note below - Used with Cat. No. 6080189

Note: Maximum system load will vary depending on application. SOMFY recommends testing of component in actual application to determine its suitability.

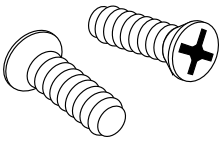

LT50/60 Mechanical Accessories

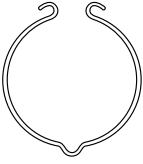
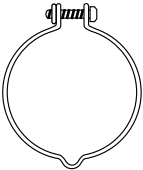

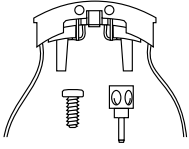
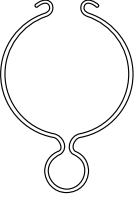
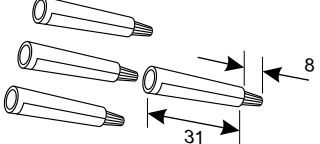
Miscellaneous

Dimensions (mm)	Cat. Number	Description
	4000551 (each) 4000555 4000556	<p>LT50 Motor Mounting Screws- Flat Head, Self Tapping Tri lobe 5mm Dia. (13mm Deep) - Used with brackets Cat. No. 6070515 and 6070516 When using screws or brackets other than by SOMFY, please contact our sales department for complete motor mounting specifications.</p> <p>LT50 RH Motor Mounting Screws - Flat Head, Self Tapping Tri lobe 4mm Dia. (9mm Deep)</p> <p>ILT RH Motor Mounting Screws - Flat Head, Self Tapping Tri Lobe 5mm Dia. (12mm Deep)</p>
	4350002	Cotter Pin - 3.5mm x 45mm
	4350026	<p>Spring Ring - Used with Brackets and Motors rated up to 80 Nm maximum - Stainless steel spring type</p>
	4350027	<p>Locking Spring Ring - Must be used with all brackets in combination with the 6100R2 motor or installations where flexing of the tube is abnormally high - Used with brackets and motors rated up to 100 Nm - Spring type stainless steel - Locking screw must be secured to prevent the motor from disengaging from the universal bracket</p>
	4350028	<p>Pull-off Tool for Spring Ring - Black finished steel</p>
	4350029	<p>Cord Setting Tool - Permits setting of the UP and Down positions when there is limited access to the motor's limit switch buttons - Instructions included</p>
	4350030	<p>Spring Ring with Loop - Used with Brackets and Motors rated up to 80 Nm maximum - Allows for easy hand removal from the bracket - Spring type stainless steel</p>
	4350031	<p>Limit Switch Button Extensions - Consists of 2 white and 2 yellow extensions</p>

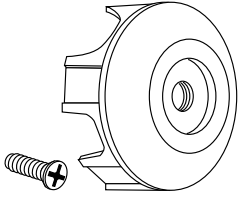
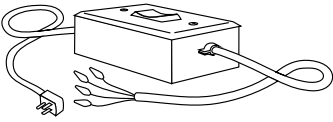
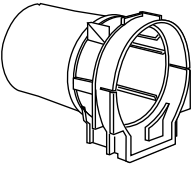

LT50/60 Mechanical Accessories

Miscellaneous

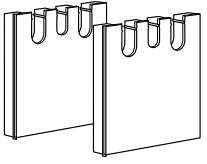
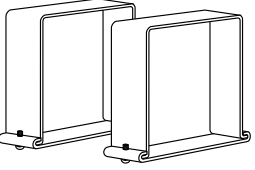
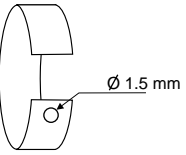
Dimensions (mm)	Cat. Number	Description
	4350032	LT50 Stop Wheel - Screws into the motor output shaft to prevent drive from coming off shaft - Instructions included - Black composite stop
	4350036	LT60 Stop Wheel - Same as above but with a screw adaptable to the LT60 operators
	6020086	Tester Cable - 4 Wire - Allows for easy setting of the LT motor limit switches before connecting the motor to the controlling device
	6020087	FTS Tester Cable - 5 Wire - Same as above, but for the FTS (Fabric Tension System)
	6180500	CTS 50 Kit
	6050185	Headrail for CTS 50
	6050186	Headrail Cover for CTS 50
	6050184	Finished Side Caps for CTS 50 Headrail
	6080183	Headrail Mounting Brackets
	6050090	Fabric Fastening Clip for 2" (50 mm) O.D. Tube - Made out of spring steel
	6050102	Fabric Fastener for 2.5" (63 mm) O.D. Tube



LT50/60 Mechanical Accessories



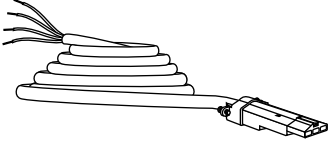
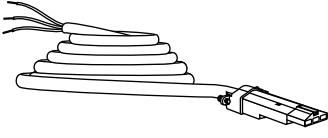
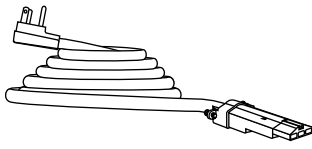
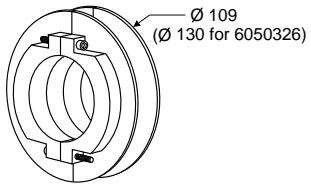
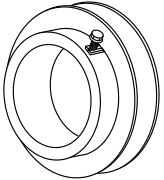
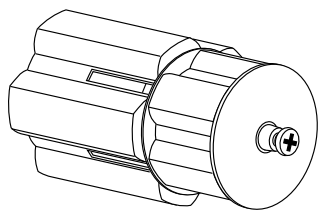







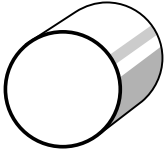

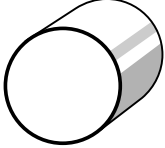

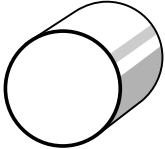
Cables and Miscellaneous

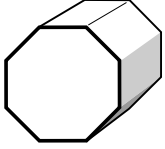
Dimensions (mm)	Cat. Number	Description
	6020500 6020501 6020502 6020505	<p><u>Standard Motor Cables Without Plug (4 wire)</u></p> <p>LT Motor Cable - 6 Ft. LT Motor Cable - 12 Ft. LT Motor Cable - 24 Ft. LT Motor Cable - 6 Ft. long with waterproof plug</p>
	6020543 6020540 6020541 6020544 6020542	<p><u>LT RTS and ILT Motor Cables Without Plug (3 wire)</u></p> <p>LT Motor Cable - 3 Ft. LT Motor Cable - 6 Ft. LT Motor Cable - 12 Ft. LT Motor Cable - 18 Ft. LT Motor Cable - 24 Ft.</p>
	6020546 6020547 6020548 6020570 6020549	<p><u>LT RTS and ILT Motor Cables With Plug</u></p> <p>Plug-in Cable with 5-15P NEMA Plug - 3 Ft. Plug-in Cable with 5-15P NEMA Plug - 6 Ft. Plug-in Cable with 5-15P NEMA Plug - 12 Ft. Plug-in Cable with 5-15P NEMA Plug - 18 Ft. Plug-in Cable with 5-15P NEMA Plug - 24 Ft.</p>
 <p>Ø 109 (Ø 130 for 6050326)</p>	6050337 6050326	<p>50 x 1.5 mm (approx. 2") Tube Cord Take-up Reel</p> <ul style="list-style-type: none"> - Material - Cast aluminum alloy - Shipped unassembled in 4 pieces - Adjustable tape width <p>63 x 1.5 mm (approx. 2.5") Tube Cord Take-up Reel</p>
	6050517 6050519	<p>2" Tube Take-up Reel (outside dia. 89mm)</p> <ul style="list-style-type: none"> - Material ABS - Maximum tape width - 9 mm <p>40mm tube take-up reel (outside dia. 66mm)</p>
	6061301 6061302 6061303 6061305	<p><u>Anti-Blocking System (ABS)</u></p> <p>ABS Wheel - Left Rotation - Maximum motor torque - 30 Nm ABS Wheel - Right Rotation - Maximum motor torque - 30 Nm The input of the ABS wheel fits the LT50 motor shaft. The output shaft will accept any of the LT50 drive wheels. Drive retaining washer is included. In the up direction, 30 Nm can be lifted. If an obstacle is detected in the down direction then the motor will spin freely and not damage the product. A momentary switch or Somfy controls having 3 min. time out are required.</p> <p>Same as above but with greater torque threshold which is required to activate the ABS</p> <ul style="list-style-type: none"> - CMO ABS left rotation - maximum motor torque - 30 Nm - CMO ABS right rotation - maximum motor torque - 30 Nm

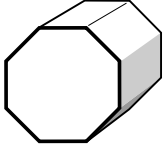

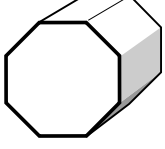

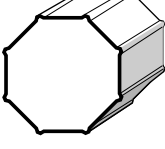







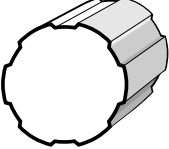

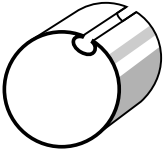

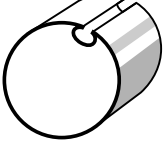

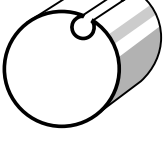

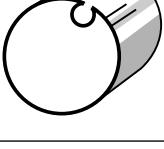
LT50/60 Mechanical Accessories

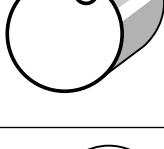
Crowns and Drives

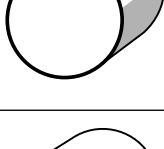
Tube Profiles	Cat. Number	Description
 	6061350 6061351	Basic Motor Crown 2.0" Round LT50 Drive (50 mm x 1.5 mm) - Soft clip 2.0" Round LT50 Drive (50 mm x 1.5 mm) - Hard clip
  	6061414 6061352 6061316 6061317	2.5" Round LT50 Crown 2.5" Round LT50 Set "Hard Clip" 2.5" Round LT Drive (63 mm x 1.5 mm) - Soft clip 2.5" Round LT Drive (63 mm x 1.5 mm) - Hard clip
  	6060158 6060181 6061353 6061400 6061354 6061318	2.75" Round LT50 Crown 2.75" Round LT60 Crown 2.75" Round LT50 Set 2.75" Round LT60 Set 2.75" Round LT Drive (70 mm x 1.5 mm) - Soft clip 2.75" Round LT Drive (70 mm x 1.5 mm) - Hard clip
  	6061385 6061415 6061355 6061386 6061356	50 mm Octagonal LT50 Crown 60 mm Octagonal LT50 Crown 60 mm Octagonal LT50 Set 50 mm Octagonal LT Drive 60 mm Octagonal LT Drive
  	9060271 6061357 6061322	70 mm Octagonal LT50 Crown 70 mm Octagonal LT50 Set 70 mm Octagonal LT Drive
  	6060306 9060271 6061331	70 mm Octagonal LT60 Crown 70 mm Octagonal LT50 Crown 70 mm Octagonal Aluminum LT50/60 Drive Wheel Kit
  	6060306 6061401 6061322	70 mm Octagonal LT60 Crown 70 mm Octagonal LT60 Set 70 mm Octagonal LT Drive

LT50/60 Mechanical Accessories

Crowns and Drives

Tube Profiles	Cat. Number	Description
  	6060653	I65 LT50 Crown
	6061366	I65 LT50 Set
	6061365	I65 LT50 Drive
  	6060428	DS 70 LT50 Crown (3 mm offset)
	6061360	DS 70 LT50 Set (3 mm offset)
	6061361 6060370	DS 70 LT Drive (0.8 -1 mm wall thickness) (3 mm offset) DS 70 LT Drive (1.2 -1.5 mm wall thickness) (3 mm offset)
  	6060585	DS 74 LT50 Crown
	6061362	DS 74 LT50 Set
	6061363	DS 74 LT Drive
  	6060619 6060473	DS 78 LT50 Crown DS 78 LT60 Crown
	6061364	DS 78 LT50 Set
	6061325	DS 78 LT Drive
  	6060855 + 6061414	DS 78/R LT50 Crown (4.4 mm offset)
	6060855	DS 78/R LT60 Crown (4.4 mm offset)
	6061324	DS 78/R LT Drive (4.4 mm offset)
  	6061126 + 6061414	DS 78/D LT50 Crown (2.5 mm offset)
	6061126	DS 78/D LT60 Crown (2.5 mm offset)
	6061326	DS 78/D LT Drive (2.5 mm offset)
  	6061238 6061216	DS 85 LT50 Crown DS 85 LT60 Crown
	6061327	DS 85 LT Drive
  	6061368	SM 65 LT50 Crown - 3 Grooves
	6061369	SM 65 LT Drive



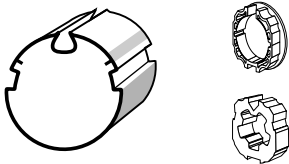
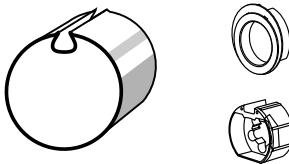
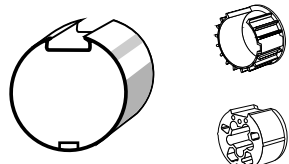
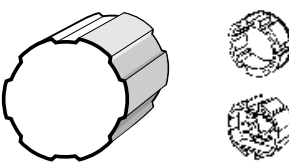
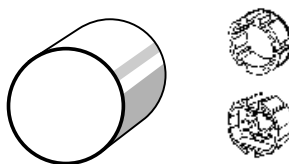
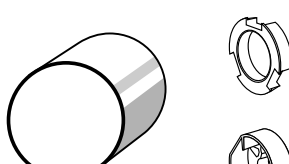
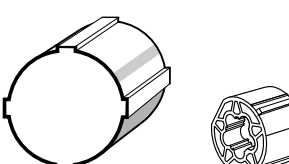

LT50/60 Mechanical Accessories

Crowns and Drives

Tube Profiles	Cat. Number	Description
	6061375	AMA71 LT50 Crown
	6061374	AMA71 LT50 Drive
	6060394	P72 LT60 Crown (4 mm offset)
	9060338	P72 LT50 Crown Set (4 mm offset)
	6061358	P72 LT50 Set (4 mm offset)
	6061323	P72 LT Drive (4 mm offset)
	6061376	LT60 Drive (78 mm)
	6061377	LT60 Crown (78 mm)
	6061092	I85 LT60 Crown
	6061115	I85 LT60 Set
	6061328	I85 LT Drive
	6060563	3.5" Round LT50 Crown (81mm x 1mm)
	6060530	3.5" Round LT60 Crown (89mm x 2mm)
	6061359	3.5" Round LT50 Set
	6061402	3.5" Round LT60 Set
	6061320	3.5" Round LT Drive (89 mm x 2 mm)
	6061319	3.5" Round LT Drive (89 mm x 1 mm)
	6060877	4.0" Round LT60 Crown
	6060934	4.0" Round LT60 Set
	6061321	4.0" Round LT Drive (102 mm x 2 mm)
	6061380	2" LT Drive for CTS 50 Tube

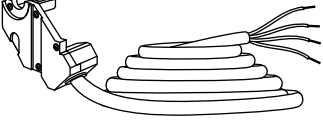

CMO Cables and Mechanical Accessories

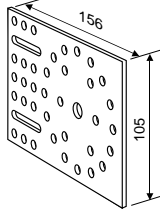
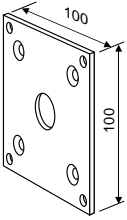
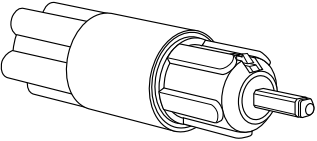
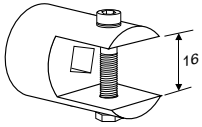

Dimensions (mm)	Cat. Number	Description
  	6020510	Standard LT CMO Motor Cable - 6 ft.
	6020511	Standard LT CMO Motor Cable - 12 ft.
	6020512	Standard LT CMO Motor Cable - 24 ft.
	6020515	Standard LT CMO Motor Cable - 6 ft. Long with Waterproof Plug
	6020550	LT RTS CMO Motor Cable - 6 ft.
	6020551	LT RTS CMO Motor Cable - 12 ft.
	6020554	LT RTS CMO Motor Cable - 18 ft.
	6020552	LT RTS CMO Motor Cable - 24 ft.
	6020557	LT RTS CMO Cable with 5-15P Right Angle NEMA Plug - 6 ft.
	6020558	LT RTS CMO Cable with 5-15P Right Angle NEMA Plug - 12 ft.
	6020560	LT RTS CMO Cable with 5-15P Right Angle NEMA Plug - 18 ft.
	6020559	LT RTS CMO Cable with 5-15P Right Angle NEMA Plug - 24 ft.
	6110500	Standard LT and LT CMO Motor Mounting Plate <ul style="list-style-type: none"> - Allows for different orientation of the LT CMO motor head in 15° increments - Zinc plated steel - Maximum motor torque - 100 Nm - Maximum system load - See note below
	6110501	CMO 100 x 100 mm LT Motor Mounting Bracket <ul style="list-style-type: none"> - Fits most shutter end caps - Allows for easy replacement of the BMOM/BMO motor utilizing existing mounting holes - Zinc plated steel - Maximum motor torque - 100 Nm - Maximum system load - See note below
	6250500	LT50 Manual Override Differential <ul style="list-style-type: none"> - The input of the differential accepts the LT50 motor shaft - The differential's output shaft can be adapted to any tube profile using the LT50 drive wheels - Maximum motor torque 40 Nm. Gain ratio 1:4 - Maximum system load - See note below
	6250505	LT50 Differential Torque Tube Connectors <ul style="list-style-type: none"> - For square link bars (16 x 1 mm) - Zinc plated steel
	6250506	<ul style="list-style-type: none"> - For round link bars (Dia. 16 x 1 mm)

Note: Maximum system load will vary depending on application. SOMFY recommends testing of component in actual application to determine its suitability.

Dimensions (mm)	Cat. Number	Description
	6250685	<p>CMO Motor Limit Setting Tool</p> <ul style="list-style-type: none"> - Allows setting the travel limits of the motor when the limit switch buttons are hard to access - Zinc plated steel
	6250700	<p>CMO Round Awning Motor Bracket</p> <ul style="list-style-type: none"> - U.S. thread 1/4 - 20, 5/16 - 18 threads - Delivered without motor mounting screws - Black finished aluminum alloy - Maximum motor torque - 100 Nm (must be used with 5/16 - 18 bolts at maximum torque) - Maximum system load - See note below
	6250701	<p>CMO ME Square Awning Motor Bracket</p> <ul style="list-style-type: none"> - U.S. thread 1/4 - 20, 5/16 - 18 threads - Delivered with two motor mounting screws (3/16" Socket Head) - Black finished aluminum alloy - Maximum motor torque - 100 Nm (must be used with 5/16 - 18 bolts at maximum torque) - Maximum system load - See note below

Note: Maximum system load will vary depending on application. SOMFY recommends testing of component in actual application to determine its suitability.

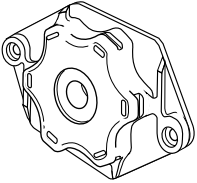
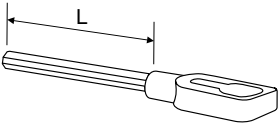

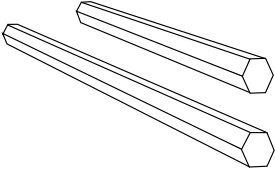
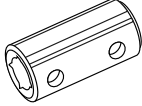
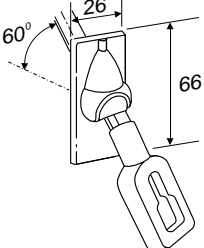
Dimensions (mm)	Cat. Number	Description
	6250702	<p>CMO Motor Bracket</p> <ul style="list-style-type: none"> - Converts a CMO motor head to be compatible with standard LT brackets - Allows the motor to be rotated in 60° increments - Delivered with two motor mounting screws - Black composite - Maximum motor torque - 80 Nm - Maximum system load - See note below
	6250710	CMO Awning Eye with 2.36" (60 mm) Long 7 mm Hex Shaft
	6250711	CMO Awning Eye with 6.5" (165 mm) Long 7 mm Hex Shaft
	6250713	CMO Awning Eye with 4" (100 mm) Long 7 mm Hex Shaft
	6250712	<p>LT CMO Awning Eye Compatible with Geiger Crank Handles</p> <ul style="list-style-type: none"> - Length of the shaft is (100 mm) 4" - Stainless steel pin for eyepiece mounting to 7 mm Hex shaft - Stainless steel stop washer & socket head screw (also sold separately) - Zinc plated steel shaft
	4100122	- Stainless steel lock washer
	4000104	- Stainless steel M4 socket head screw
	6250715	<p>CMO Extension Shafts</p> <ul style="list-style-type: none"> - 7 mm Hex, 8.66" (220 mm) long - Zinc plated steel
	6250716	<ul style="list-style-type: none"> - 7 mm Hex, 13" (330 mm) long - Zinc plated steel
	6250717	<p>Connecting Sleeves</p> <ul style="list-style-type: none"> - 7 mm Hex to diameter 11.3 mm - Zinc plated steel
	6250718	<ul style="list-style-type: none"> - 7 mm Hex to 8 mm Square - Zinc plated steel
	6250719	<ul style="list-style-type: none"> - 7 mm Hex to 7 mm Hex - Zinc plated steel
	6250720	<p>CMO Extension Shaft with Universal Joint</p> <ul style="list-style-type: none"> - Shaft 7 mm Hex, 12.4" (315 mm) long - zinc plated steel - Output of the universal joint is a 12 mm diameter hole - Universal joint - White powder coated steel - Color: white fixing plate - 60° outlet

Note: Maximum system load will vary depending on application. SOMFY recommends testing of component in actual application to determine its suitability.

Dimensions (mm)	Cat. Number	Description
	6250721	<p>CMO Extension Shaft with Awning Eye and Plate</p> <ul style="list-style-type: none"> - Shaft 7 mm Hex, 10.25" (260 mm) long- Zinc plated steel - Color: white fixing plate with black awning eye - 60° outlet
	6250723	<p>LT CMO 70 Degree, 4 Hole Plate SS Crank Handle Universal Joint</p> <ul style="list-style-type: none"> - Compatible with 14 mm diameter bell type connectors - Material: Stainless steel and nickel plated zinc casting plate - 7 mm hex shaft: Steel, zinc plated
	6250724	<p>LT CMO 90 Degree, 2 Hole Plate SS Crank Handle Universal Joint</p> <ul style="list-style-type: none"> - Material: Stainless steel and nickel plated zinc casting plate
	6250725	<p>LT CMO 90 Degree, 4 Hole Plate SS Crank Handle Universal Joint</p>
	6250730	<p>7 mm Hex to 7 mm Hex Universal Joint Adaptor</p>
	6250731	<p>7 mm Hex to 8 mm Square Universal Joint Adaptor</p>
	6250732	<p>7 mm Hex to 8 mm Square Double Universal Joint Adaptor</p>



LT50/60 and LT50/60 CMO Mechanical Accessory Kits

Product Kit	Cat. Number	Description of Parts	Quantity
U.S. 3/4 inch SS Hardware Kit	6180001		
	4000075	1/4 - 20 x 3/4 hex head SS 18-8 bolt	2
	4200013	1/4 flat washer SS 18-8	2
	4200014	1/4 split lock washer 18-8	2
U.S. 1 inch SS Hardware Kit	6180002		
	4000100	1/4 - 20 x 1 hex head SS 18-8 bolt	2
	4200013	1/4 flat washer SS 18-8	2
	4200014	1/4 split lock washer 18-8	2
U.S. 1.25 inch SS Hardware Kit	6180003		
	4000125	1/4 - 20 x 1.25 hex head SS 18-8 bolt	2
	4200013	1/4 flat washer SS 18-8	2
	4200014	1/4 split lock washer 18-8	2
Metric 20 mm SS Hardware Kit	6180005		
	4000461	M6 x 20 mm hex head cap screw SS	2
	4100121	Lock washer split M6 SS A2	2
	4200015	M6 flat washer SS A2	2
Metric 25 mm SS Hardware Kit	6180006		
	4000462	M6 x 25 mm hex head cap screw SS	2
	4100121	Lock washer split M6 SS A2	2
	4200015	M6 flat washer SS A2	2
Metric 30 mm SS Hardware Kit	6180007		
	4000454	M6 x 30 mm hex head cap screw SS	2
	4100121	Lock washer split M6 SS A2	2
	4200015	M6 flat washer SS A2	2



LT50/60 and LT50/60 CMO Mechanical Accessory Kits

Product Kit	Cat. Number	Description of Parts	Quantity
CMO Round Awning Override Kit	6180700		
	4000125	1/4 - 20 x 1.25 hex head SS18-8 bolt	2
	4000464	1/4 - 20 x 7/8 socket head cap screw	2
	4100116	Nut hex 1/4 - 20 18-8 SS	2
	4200013	1/4 flat washer SS 18-8	4
	4200014	1/4 split lock washer 18-8	2
	6250700	CMO awning bracket with US thread	1
	6250710	CMO awning override short shaft	1
7000052	Plastic bag 5 x 6 x .04	1	
CMO ME Square Awning Override Kit	6180701		
	4000075	1/4 - 20 x 3/4 hex head SS 18-8 bolt	2
	4000125	1/4 - 20 x 1.25 hex head SS18-8 bolt	2
	4100116	Nut hex 1/4 - 20 18-8 SS	2
	4200013	1/4 flat washer SS 18-8	4
	4200014	1/4 split lock washer 18-8	2
	6250701	CMO awning bracket with ME US thread	1
	6250710	CMO awning override short shaft	1
7000052	Plastic bag 5 x 6 x .04	1	
CMO Awning Kit without Awning Eye	9250700		
	4000125	1/4 - 20 x 1.25 hex head SS18-8 bolt	2
	4000464	1/4 - 20 x 7/8 socket head cap screw	2
	4100116	Nut hex 1/4 - 20 18-8 SS	2
	4200013	1/4 flat washer SS 18-8	4
	4200014	1/4 split lock washer 18-8	2
	6250700	CMO awning bracket with US thread	1
	7000052	Plastic bag 5 x 6 x .04	1
CMO ME Awning Kit without Awning Eye	9250701		
	4000075	1/4 - 20 x 3/4 hex head SS 18-8 bolt	2
	4000125	1/4 - 20 x 1.25 hex head SS18-8 bolt	2
	4100116	Nut hex 1/4 - 20 18-8 SS	2
	4200013	1/4 flat washer SS18-8	4
	4200014	1/4 split lock washer 18-8	2
	6250701	CMO ME awning bracket with US thread	1
	7000052	Plastic bag 5 x 6 x .04	1

SOFT CLIP (Removable)

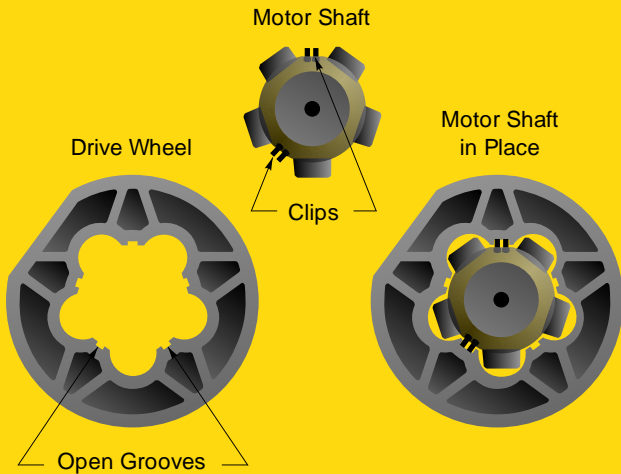

HARD CLIP (Fixed)

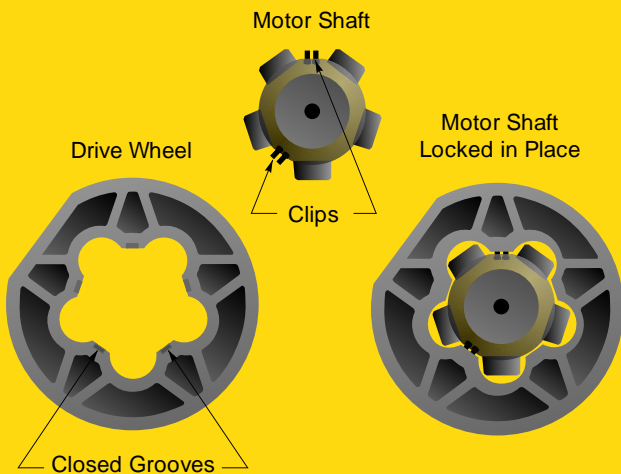

Installation of the drive wheel to the motor shaft:
Push the drive into the motor shaft until you hear a "click". Two clips lock the drive wheel into the motor shaft.

There are two types of LT drive wheels: Removable or "Soft Clip" type, and fixed or "Hard Clip" type.

The "Soft Clip" drives are available only for round tubes in 2", 2.5" and 2.75" diameters. The drive wheel can be removed by physically pulling it off the motor shaft. For the ease of identification all "Soft Clip" drives are brown.

The "Hard Clip" drives can only be removed from the shaft by pressing the two clips inward at the same time. The motor must be out of the tube in order to have access to the clips. These drives are black.

Installation in round tubes:

The drive must be riveted to the tube after the motor is inserted. See page 62 for required fastener size and quantity.

Installation in profiled tubes:

The drive doesn't need to be riveted to the tube because it is already in a positive lock position within the profiled tube.



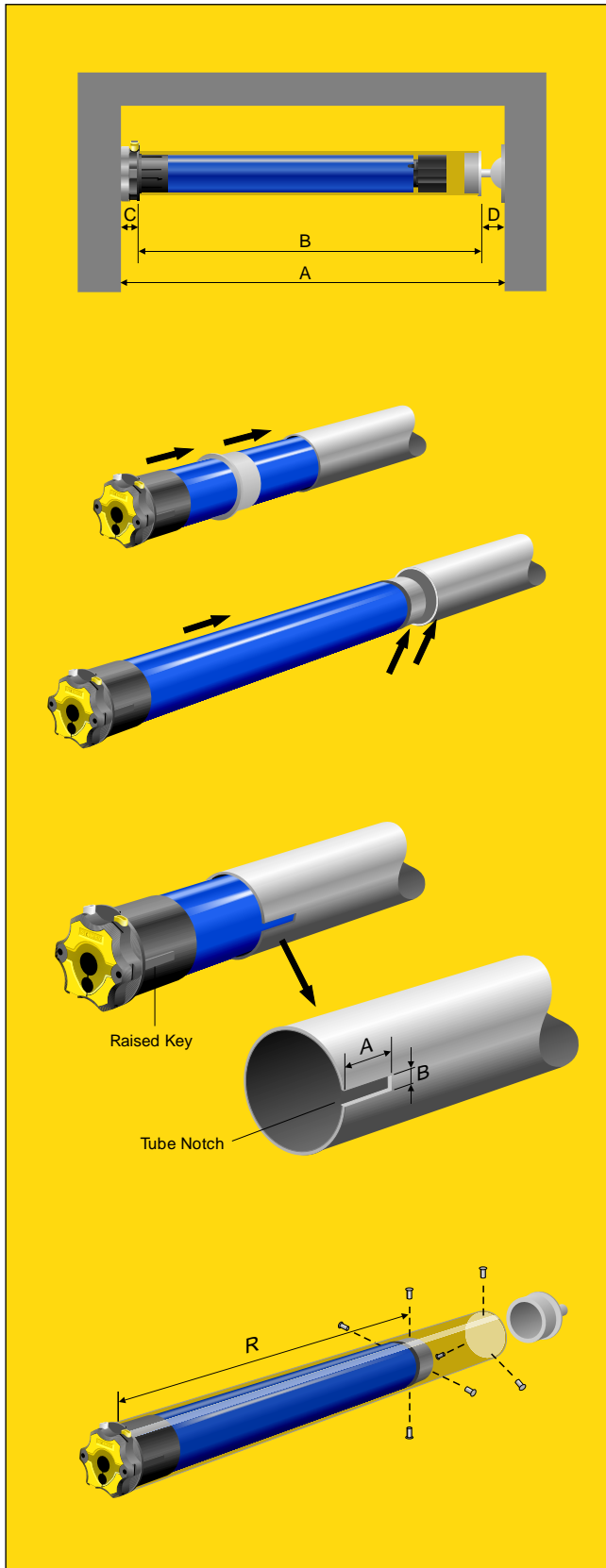

Determining the Tube Length (B):

Clear dimension (A)

- Space requirement for motor bracket (C)
- Space requirement for idler bracket (D)

= Tube length (B)

The dimensions for the lateral space requirement for the motor brackets and idler brackets depends on the bracket design in each instance. They also include the space requirements for the motor head which are listed on pages 10-12.

Installation

- Attach motor brackets
- Provide opening for the motor cables
- Install the motor in the tube. Only push the motor into place. **Never hit into place with a hammer!**

Profiled Tubes

Push on the motor crown and drive wheel (which fit the pre-finished tube) and slide motor inside the tube.

Round Tubes

Notch the tube on the motor side for the basic motor crown and push on the drive wheel. Now slide the motor into the tube in such a way that the raised key of the crown comes to rest in the cut notch.

	<u>A</u>	<u>B</u>
Notch: LS40	Length = 8.5 mm	Width = 6 mm
LT50	25 mm	4 mm
LT60	35 mm	8 mm

Rivet or screw the drive wheel in place at four points at a distance **R** from the motor side.

- Self Tapping screws: 4 pcs., 5 x 10mm
- Blind rivets: 4 pcs., diameter 5mm, steel

NOTE: To ensure a safe installation, we recommend that the idler end cap be secured to the tube with 3 blind rivets.

When using fasteners other than supplied by SOMFY, it is imperative that they are of steel SAE Grade 5 or higher. (8.8 for metric fasteners), accompanied with locking type washers.

NOTE: When selecting mechanical accessories the following specifications must be followed:

- Maximum motor torque rating of the components
- Static (dead) load of all system components supported by the motor head and mounting brackets must be within their capacity
- Effective motor torque is equal to the maximum motor torque less torque losses in the system due to friction, misalignment etc... For design purposes SOMFY recommends this value to be 70% of the maximum motor torque.

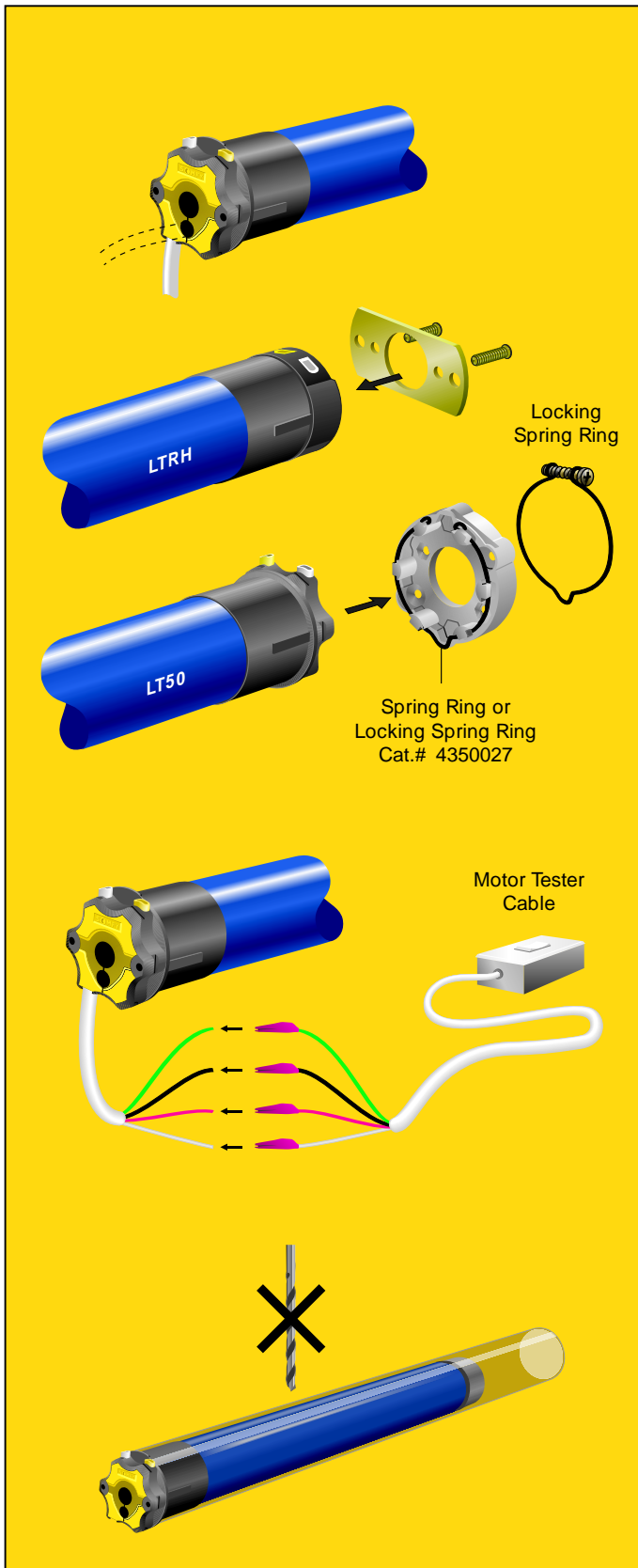

Motor Cable Positioning

Depending on the application, the motor cable can pass through the center or side of the motor head. In the LT50/60 versions simply raise the yellow cover plate slightly, reposition the cable and then press the cover plate into place.

Mounting the Motorized Tube

LS40 and LT50 RH

The motor brackets for the LS40 and LT50 RH are screwed directly into the head of the motor as illustrated at left.

LT50/60

The motor brackets for the LT50/60 are equipped with a spring ring. This spring ring must be used and does not have to be removed for installation. You can press the motor axially into the motor bracket in any of 6 positions, so that the limit switch adjustment buttons are always easily accessible. When the motor engages the motor bracket, the spring ring makes a click sound. The spring ring keeps the motor head securely seated in the bracket for even torque distribution. For higher torque applications a locking spring ring with screw must be used in place of the standard spring ring.

Testing the Motor - Test Run 1

- Connect the motor tester cable (Cat. No. 6020086) to the motor cable, match the wire colors and connect to power.
 - Remove yellow protective cap from limit switch adjustment buttons.
 - Press both limit switch adjustment buttons in (they will automatically remain locked).
- When the limit switch adjustment buttons are pushed in, the motor has no stop position shut-off points. The number of revolutions is unlimited.

Attaching Rolling Shutter, Awning, Screen...

Now you can attach the interior, or exterior window treatment to the tube.

Caution! Never drill in the vicinity of the motor, or use screws that could penetrate the motor.

Adjustment of Upper and Lower Positions for LT50/60 motors

- Both limit switch adjustment buttons have been depressed since Test Run 1.

Stop Position 1

- Bring end product into the desired stop position 1 (direction of rotation 1)
- Release the limit switch adjustment button that lies in the direction of rotation 1 by pressing it down again. Stop position 1 is now set.

LT50/60 and LT50RH

Stop Position 1

Depending upon type of installation

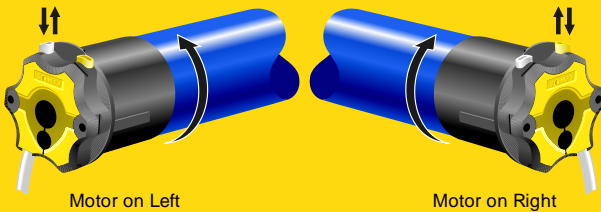

Position 2

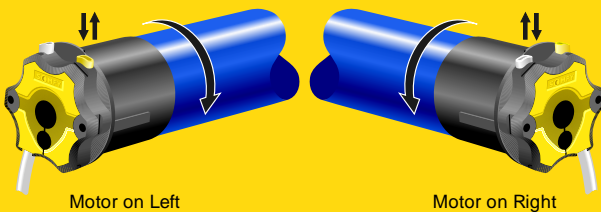

LS40

Stop Position 1

Depending upon type of installation

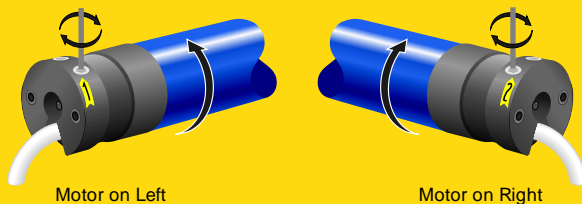

Stop Position 2

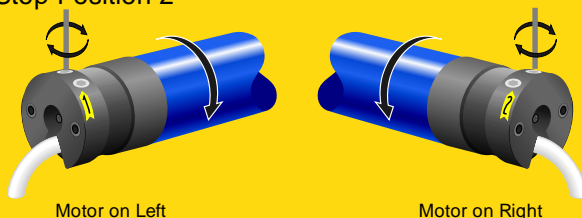

Stop position 2

- Bring end product into stop position 2 (direction of rotation 2)
- Release the limit switch adjustment button that lies in the direction of rotation 2 by pressing it down again. Stop position is now set.

Always attach protective cap over limit switch adjustment buttons.

NOTE: It is important to note that SOMFY motors are weatherproof, but **NOT WATERPROOF** and therefore the motor head should not be exposed to direct rainfall.

Test Run 2

Allow the motor to run in both directions, until it shuts off in the stop positions. Because of the built-in thermal protection feature, the motor may shut off automatically after running without interruption for an extended period of time. Please wait until the motor has cooled off and is ready for operation again (approximately 10-15 minutes).

Changing a Set Stop Position...

- Press the limit switch adjustment button that lies in the direction of rotation.
- Bring the end product into the desired stop position.
- Release the limit switch adjustment button by pressing it down again.

Adjustment of Upper and Lower Positions for the LS40 Motor

- Connect the motor tester cable (Cat. No. 6020086) to the motor cable, match the wire colors and connect to power.
- Identify the UP recessed limit screw by finding the arrow on the motor head which points in the direction that retracts (rolls up) the system.
- Turn the power on to ensure that the switch is operating properly (UP-raises, DOWN-lowers). If not, turn the power off and simply reverse the black and red motor leads.
- Flip the tester cable switch in the UP direction. If the system stops before its UP limit, turn the UP screw to "+" until necessary. If the system does not stop at its UP limit, flip the tester cable switch off and turn the UP screw to "-". Repeat this until correct setting is achieved.

NOTE: 7 Turns of Hex Screws equals 1 turn of roller tube.

- Flip the tester cable switch in DOWN direction. If the system stops before its DOWN limit, turn the DOWN limit screw to "+". If not, flip the tester cable switch off and turn the DOWN limit screw to "-". Repeat this until correct setting is achieved.

NOTE: Recessed thumbscrews can accommodate a flat head screwdriver, SOMFY's Allen wrench or Flexible limit switch adjuster.



LT50/60 CMO and LT50 RTS CMO

Programming and Limit Setting Instructions

For initial programming, provide power only to the motor being programmed.

For awning installations, an awning hood is strongly recommended and a drip loop should be formed to prevent water from entering the head of the motor as shown in Fig. (1).

Follow the steps below to program the motor and set the limits.

1) Provide power to the motor.

Remove cap as shown in Fig. (2) and depress both limit switch buttons until they lock in the down position.

To assign the transmitter to communicate with the motor, push the **UP** and **DOWN** buttons on the transmitter simultaneously until the motor jogs briefly up and down then release. See Fig. (3).

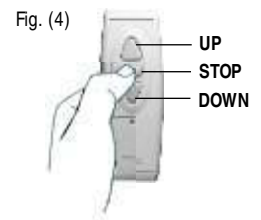
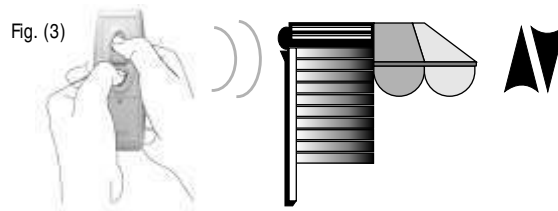
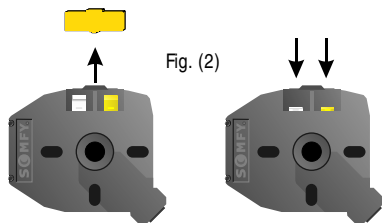
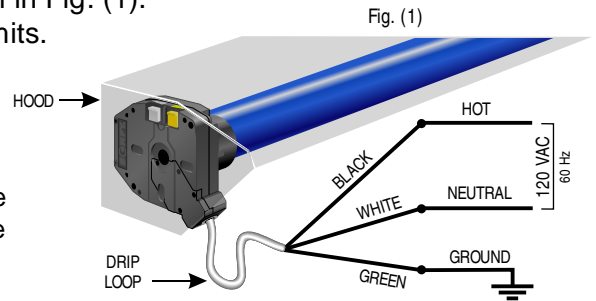

2) Check the direction of operation.

The **DOWN** button should correspond with the down direction of the end product (for awnings **DOWN** extends the awning).

If the direction is wrong, press the **STOP** button on the transmitter as shown in Fig. (4) until the motor jogs. Check the direction again to make sure it is correct.

3) Setting the UP and DOWN limits

Press the **UP** button of the transmitter until the end product reaches the required UP position, then stop it.

Unlock the UP limit switch on the motor head by pressing and releasing it. The UP limit is now set.

Repeat the above operation to set the DOWN limit.

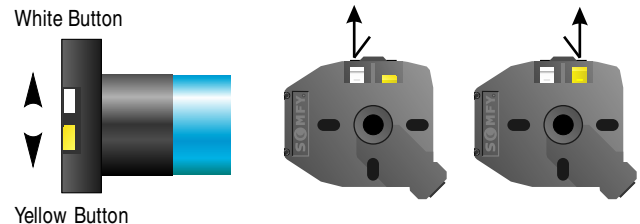

4) Recording the settings on your transmitter

Press the programming button on the back of the transmitter and release when the product jogs briefly UP and DOWN.

The transmitter is now memorized into the motor.

Note: On 4 channel transmitters, verify the desired channel selection before pressing the programming button.

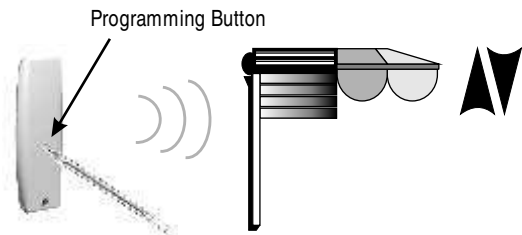

5) Setting the intermediate position

Upper Intermediate Position: Bring the product to its upper limit. Press the **STOP** and **DOWN** buttons simultaneously then release. When the product reaches the desired intermediate position, press the **STOP** button. Make adjustments if needed. Press the **STOP** button again until the motor jogs then release.

Lower Intermediate Position: Bring the product to its lower limit. Press the **STOP** and **UP** buttons simultaneously then release. When the product reaches the desired intermediate position, press the **STOP** button. Make adjustments if needed. Press the **STOP** button again until the motor jogs then release.

6) Adding and deleting a transmitter or transmitter channel

To **Add** a transmitter/channel, press the programming button of an already recorded one until the motor jogs. Select the transmitter/channel to add and press the programming button until the motor jogs.

To **Delete** a transmitter/channel, press the programming button of an already recorded one until the motor jogs. Select the transmitter/channel to delete and press the programming button until it jogs.

Note: These instructions are for reference only. For more detailed instructions please refer to the installation instructions packaged with the motor or at www.somfysystems.com under "Technical Documentation".

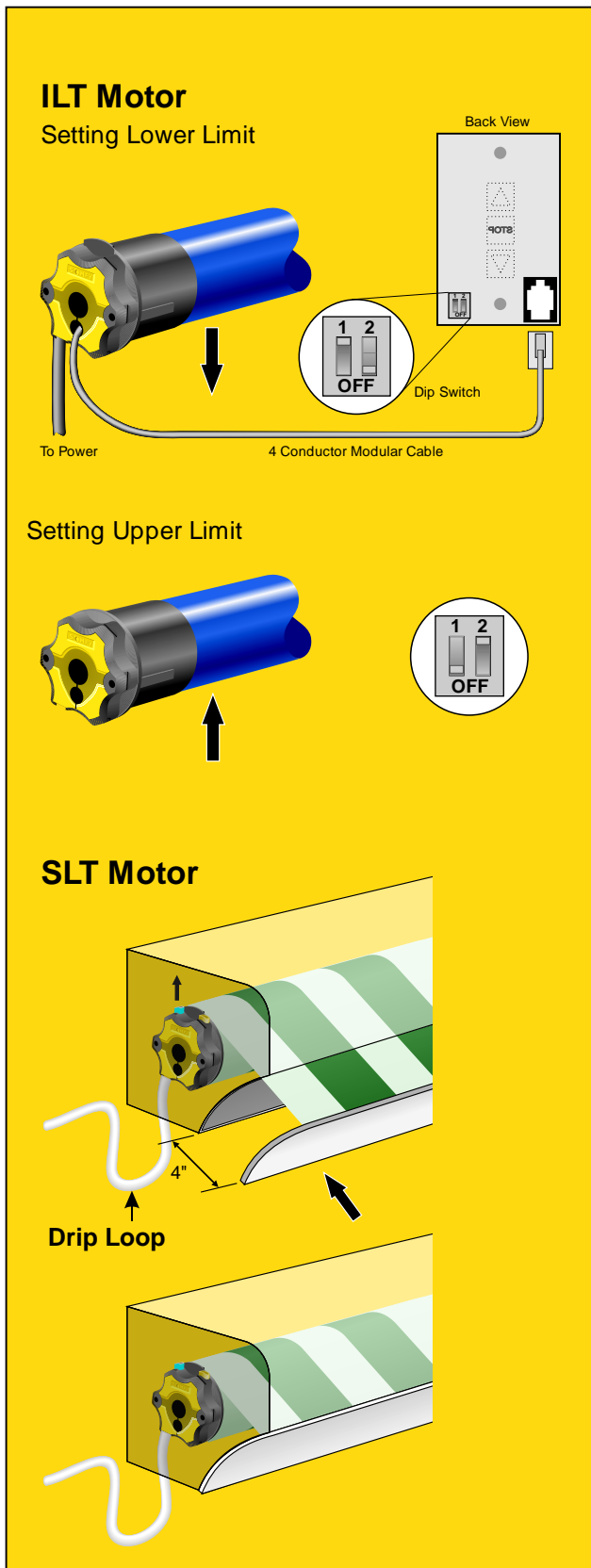

ILT Motor

- The “electronic limits” of SOMFY’s ILT motors are set from the Decorator ILT switch. It controls and sets the limits of a single motor.

Setting the Limits

- Connect the ILT switch to the motor's modular cable.
- Set the dip switch (located on back of switch) with 1 ON and 2 OFF. Press and hold the DOWN arrow on the switch to move the window treatment to the desired lower limit. If the treatment moves in the opposite direction, release the DOWN button and depress the STOP button for 2 seconds. This will reverse the operation of the UP and DOWN buttons.
- Move the motor to the desired lower limit and return both dip switches to OFF. The lower limit is now set.
- Set the dip switch with 1 OFF and 2 ON. Move the window treatment to the desired upper limit by pressing and holding the UP button on the ILT switch. Return both dip switches to OFF. The upper limit is now set.
- To set an intermediate position, move the window treatment to the desired position and press the STOP button, holding it for at least 5 seconds. Afterwards, the window treatment will move to the intermediate position by simply pressing the STOP button while the motor is at rest.
- For operation of the ILT switch, please refer to ILT switch Instructions.

SLT Motor

- The SLT motor comes in two versions: Left Mount (blue and yellow buttons), and Right Mount (blue and white buttons). Please make sure that you have the correct version for your installation.

Setting The Limits

- The setting of the SLT motor limits is the same as the standard LT motor with one exception. The upper limit setting which is always controlled by the blue button must be set as follows:
- Press down the blue button until it locks in a down position.
- Using the SOMFY tester cable retract the awning to approximately 4 inches from closing.
- Release the blue limit switch adjustment button.
- The upper limit is now set.
- If the blue button does not correspond to the upper limit, then the wrong type of motor is being used.



Altus RTS and Orea RTS Motor

Programming and Limit Setting Instructions

(Note: Orea RTS motor was designed for cassette awnings only)

1 Factory Mode

In this mode the transmitter has not been assigned to communicate with the motor and the limits have not been set

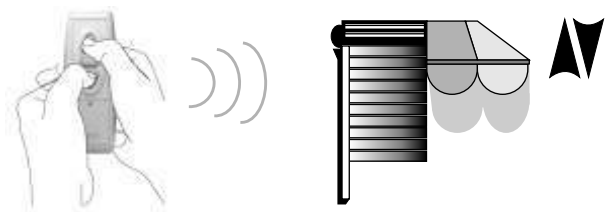

1) To assign the transmitter to communicate with the motor's receiver, push the UP and DOWN buttons on the transmitter SIMULTANEOUSLY and release the buttons after the end product jogs briefly UP and DOWN indicating the transmitter can now operate the motor for programming. The motor will now operate in a momentary fashion.

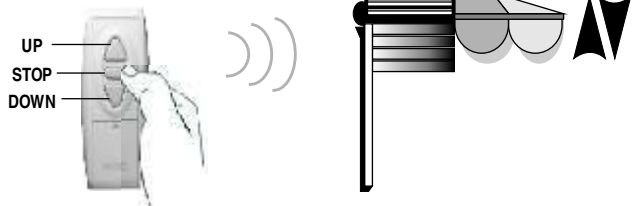

2) Check direction of operation. The DOWN button must correspond to DOWN on the motor. In the case of an awning, it will open or extend the awning. If the direction is wrong, press the STOP button on the transmitter until the motor jogs briefly UP and DOWN (approx. 5 seconds) and then release. Verify that the direction has changed and now corresponds to the transmitters UP and DOWN buttons.

3) Adjust the end product to the up position. This is necessary to establish a reference starting point. Read the complete limit setting procedure before proceeding with setting the UP and DOWN limits.

4) Setting of the END LIMITS (always start at the upper reference point (UP limit).
Note: an extension of 4" is required as a starting point for the Orea RTS (cassette awning motor) only.

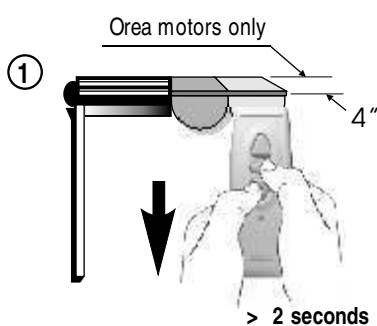

A. To set the DOWN limit, press the STOP and DOWN buttons for more than 2 seconds, until the product begins moving down (Fig. 1). Release the buttons once the product begins to move, and be prepared to stop it at its DOWN limit.

B. Press the STOP button to stop the motor when it reaches the desired down position (Fig. 2). The DOWN limit is now set.

If necessary, adjust the correct down position using the UP and DOWN buttons. Remember at this point the motor moves for only as long as you keep your finger on the button (momentary operation).

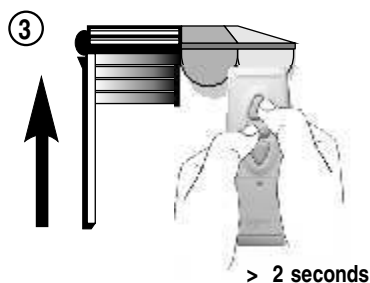
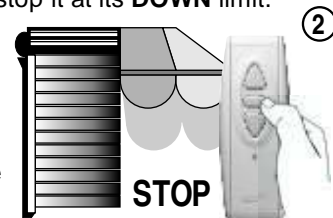

C. To set the UP limit, press and hold the STOP and UP buttons for more than 2 seconds, until the product begins to move up (Fig. 3). Release the buttons once the product begins to move. It will stop at its upper limit automatically. Adjust if necessary using the UP or DOWN buttons.

NOTE: It is not necessary to adjust the UP limit on an OREA RTS motor since it is automatically set once the cassette awning is completely closed.

D. To confirm these limit positions, press and hold the STOP button for more than 2 seconds, until the application jogs briefly UP/DOWN (Fig. 4), indicating the limits have been memorized by the motor. The setting of the end limits is now complete.

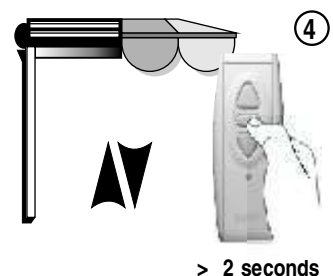

2 Installer Mode

In this mode the **UP** and **DOWN** limits have been set and can be readjusted if necessary as shown below.

- 1) Provide power to the motor. Press the **UP**, **STOP** or **DOWN** button (independently) on any RTS transmitter in order to take control of the motor. Check that the motor is in **INSTALLER MODE**. (Motor responds to transmitter in momentary fashion)
- 2) Recording the first Transmitter or Channel (On 4 channel transmitters, you should select the desired channel before pressing the programming button).

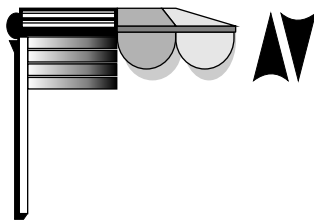

- A. Press the programming button on the back of the RTS transmitter and release it when the end-product jogs briefly **UP/DOWN** indicating that the transmitter has been memorized into the motor

3) Readjusting the **UP** or **DOWN** limit after the transmitter has been programmed.

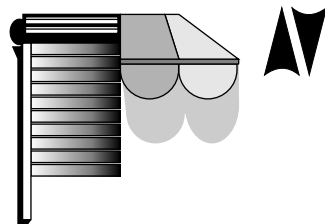

- A. To readjust the down or awning extended limit, first bring the product all the way to its **DOWN** limit using the transmitter. The motor must reach the **DOWN** position on its own.
- B. After the motor has stopped, press the **UP** and **DOWN** buttons simultaneously for 5 seconds or more until the product jogs briefly **UP/DOWN** indicating that the motor is in the "END LIMIT SETTING STATE".

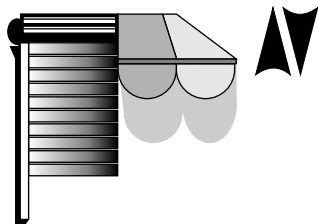
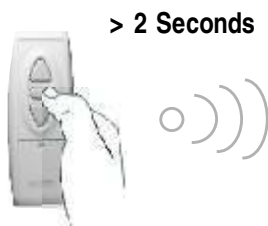

- C. Now adjust the product to its new **DOWN** limit keeping in mind that the motor will respond to the transmitter in a momentary fashion.
- D. Record the new **DOWN** limit by pressing the **STOP** button for 2 seconds or more until the product jogs briefly **UP/DOWN** indicating the change has been memorized in the motor.

The new **DOWN** limit has been recorded.

- E. Repeat the same procedure for the **UP** or retracted limit, if necessary. OREA RTS motors automatically adjust their **UP** limit and never need to be readjusted.

3 User Mode

In this mode the product is ready for operation by the end user.

One Intermediate Position (IP) can be programmed into the ALTUS/OREA RTS motor as shown below.

1) Recording the Intermediate Position (IP)

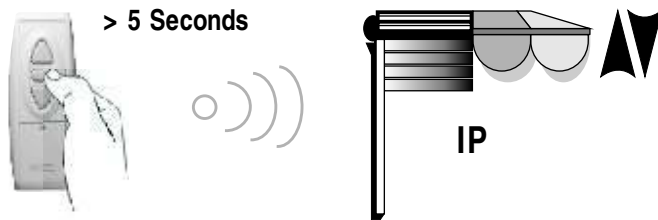

- A. Using the UP or DOWN button on your transmitter bring the product to the desired intermediate position and press STOP.
- B. Now press the STOP button again for 5 seconds or more until the end-product jogs briefly UP/DOWN indicating that the intermediate position has been memorized in the motor.

USING THE INTERMEDIATE POSITION

Manually: Press the intermediate button (STOP button) when the motor is not in motion.

Automatically: When the SOLIRIS RTS sensor reaches the set DAYLIGHT THRESHOLD, it gives a DOWN command. The end-product will move to the intermediate position only if the intermediate position has been programmed. Otherwise it will move to the DOWN limit.

TO DELETE THE INTERMEDIATE POSITION

Reach the intermediate position. Then press on the STOP button and hold it (approx. 5 sec.) until the end-product jogs briefly. The IP has been deleted.

2) Add or Delete a transmitter/channel in the memory of the ALTUS/OREA RTS motor. The procedure is the same whether you're adding or deleting a channel. If the transmitter/channel has not been previously memorized it will be added instead of deleted.

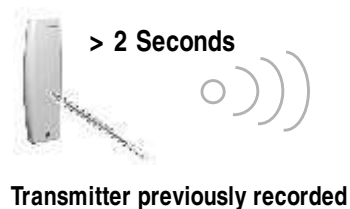

Activate the motor memory by pressing the programming button of the transmitter/channel already recorded in the motor's memory for more than 2 seconds.

Release it after the end-product jogs briefly UP/DOWN indicating that the motor is in PROGRAMMING STATE.

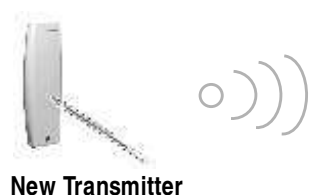

Select the transmitter/channel you wish to memorize in the motor. Press briefly on the programming button of the new RTS control you wish to assign or delete.

Release it after the end-product jogs briefly UP/DOWN indicating that the transmitter has been memorized or deleted in the ALTUS/OREA RTS motor.

Repeat this procedure for each additional transmitter/channel you wish to add or delete. It is not possible to delete the transmitter/channel used to enter the programming state.

3) Resetting the motor's memory and recording a new transmitter when the only transmitter is lost.

! NEW TRANSMITTER

** A. Perform a double power cut in the following sequence:

1. Power-off - 2 sec. minimum
2. Power-on - 5 to 15 seconds
3. Power-off - 2 sec. minimum
4. Power-on

The end product moves for 5 seconds in one direction, to indicate that the double power cut has been recorded. The motor is in a PROGRAMMING STATE for 2 minutes.

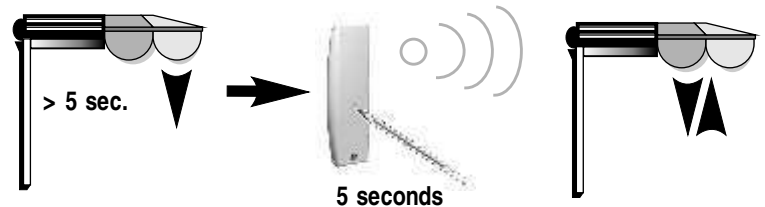

B. Recording a New Transmitter

Press the programming button of the NEW RTS transmitter for 1 second max. Release it after the end-product jogs briefly UP/DOWN indicating that the transmitter has erased all previous transmitters and recorded the NEW one.

C. Restoring Factory mode with a New Transmitter

Press and **HOLD** the programming button of the NEW RTS transmitter for more than 7 seconds. The end-product will jog briefly UP/DOWN twice. Once after 1 second and again after 7 seconds. This indicates the ALTUS/OREA RTS motor has been completely cleared.

** RESETTING MOTORS BACK TO USER MODE

WARNING: This type of power cut affects all the ALTUS RTS motors on the same power line. To avoid resetting of non-concerned motors, press briefly any button of their assigned transmitter/channel (UP, STOP, or DOWN). The non-concerned motors will return to USER MODE.

4) Back to the factory configuration (to completely reset the ALTUS RTS motor memory)

** A. Perform a power cut in the following sequence:

1. Power-off - 2 sec. minimum
2. Power-on - 5 to 15 seconds
3. Power-off - 2 sec. minimum
4. Power-on

The end product moves for 5 seconds in one direction, to indicate that the double power cut has been recorded. The motor is in PROGRAMMING STATE for 2 minutes.

! PREVIOUSLY RECORDED TRANSMITTER

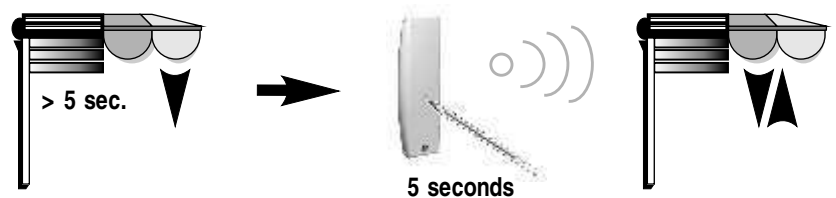

B. Restoring Factory Mode with a Previously Recorded Transmitter

Press and **HOLD** the programming button of the NEW RTS transmitter for more than 7 seconds. The end-product will jog briefly UP/DOWN twice. Once after 1 second and again after 7 seconds. This indicates the ALTUS/OREA RTS motor has been completely cleared.

LT50/60

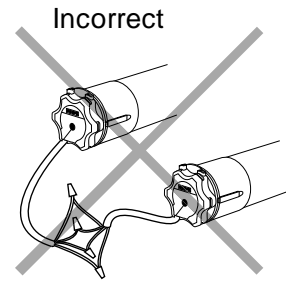
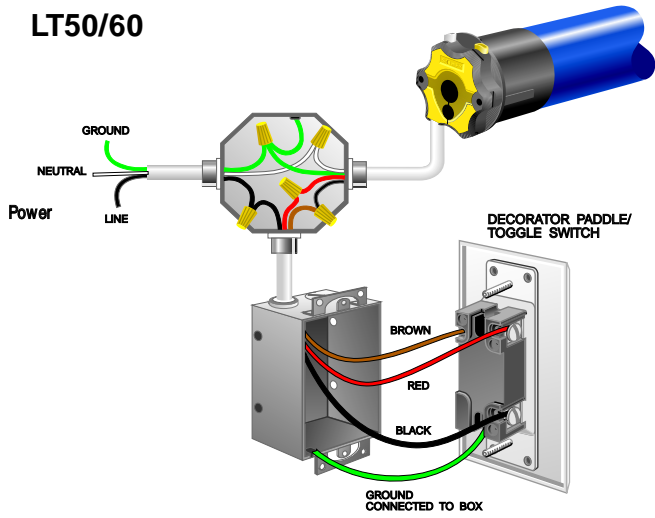

WARNING:

Do not wire two or more LT operators to one single pole switch. This will cause the motors to malfunction.

LT50/60 CMO

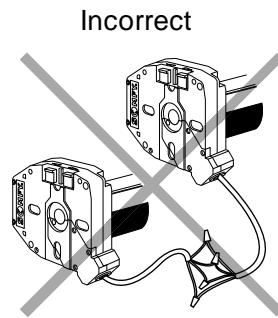
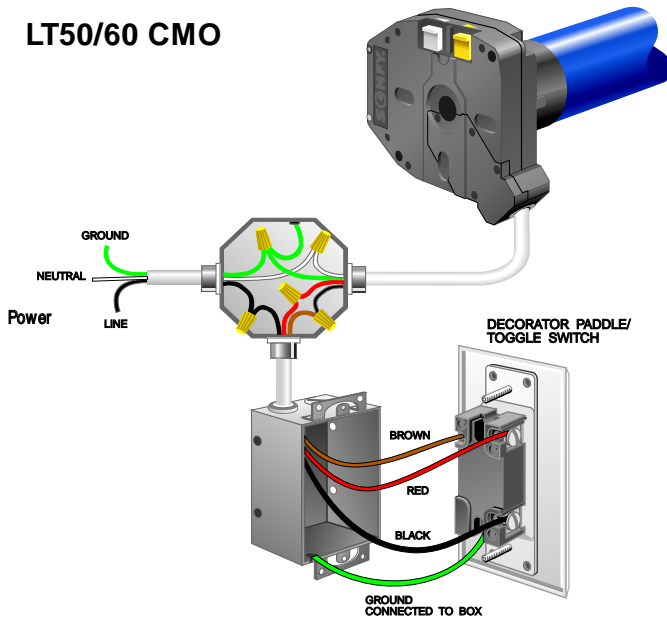

LT50 ALTUS RTS

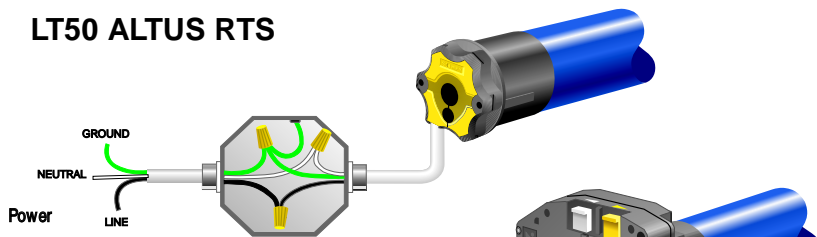

LT50 RTS CMO

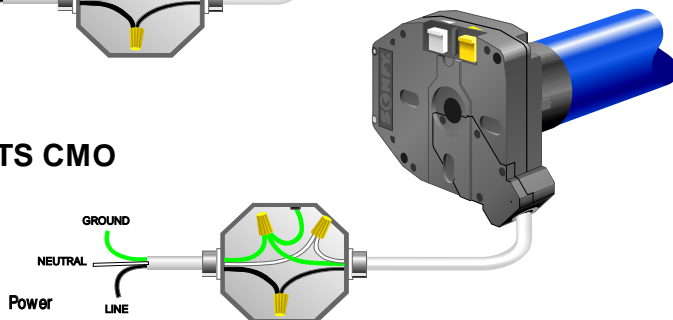

LT MOTOR WIRING COLOR CODE

120V AC	CODE
BLACK	WHITE PUSH-BUTTON
RED	YELLOW PUSH-BUTTON
WHITE	(C) COMMON
GREEN	(G) GROUND

Note: Only RTS and ILT motors can be wired in parallel.

LT50 ALTUS RTS AND LT50 RTS CMO MOTOR WIRING COLOR CODE

120V AC	CODE
BLACK	(H) HOT
WHITE	(N) NEUTRAL
GREEN	(G) GROUND

Because of the type of motor (Asynchronous with built-in capacitor) and the built-in limit switches, it is important to follow two important recommendations to assure proper operation of the motorized systems - SOMFY Operators are not universal motors.

SYMBOLS			
M1	Microswitch	W2	Motor Winding
M2	Microswitch	TP	Thermal Protector
C	Capacitor	GND	Ground
W1	Motor Winding		

The operator is connected to a 120V-60HZ power source through a single pole (or double pole), double throw, center off switch.

1. Do Not Wire SOMFY Operators in Parallel (Does not apply to RTS or ILT motors). Parallel Wiring Means: Several Operators are Wired to Only One Electrical Contact Per Direction of Rotation.

There will be constant feedback from one motor to another, so stopping points will not be stable and there is a risk of motor burn out.

Correct:

Correct wiring solution is to use a double pole, double throw, center off switch which would isolate both motors.

Incorrect:

Motor A stops at its limit in direction 2 before Motor B. Current in Motor B feeds back to motor A through capacitor C2 and microswitches M3 and M1. Both operators keep rotating in opposite directions at reduced power.

2. Do Not Control One SOMFY Operator from Several Locations Without Using Proper Controller.

Correct:

Possible problem: When switch (1) is turned on, the motor will begin running in direction 1. As it reaches its limit, the microswitch M1 will open. If, at the same moment in time switch (2) is turned on, the motor will operate in the opposite direction. This is why we recommend the use of momentary switches with the Multi-Switch Command (MSC).

Incorrect:

The microswitch M1 closes, shortcircuiting the capacitor which is loaded at its maximum voltage (180V). As a result the microswitch M1 is damaged.

Solution: Use relays to build priorities between controls sending opposite signals. Do not use a standard "light" switch as a motor control.

NOTE: SOMFY Control Systems are designed to comply with these two basic criteria and assure reliable operation of motorized systems. Non-compliance to these two basic principles voids the SOMFY warranty.

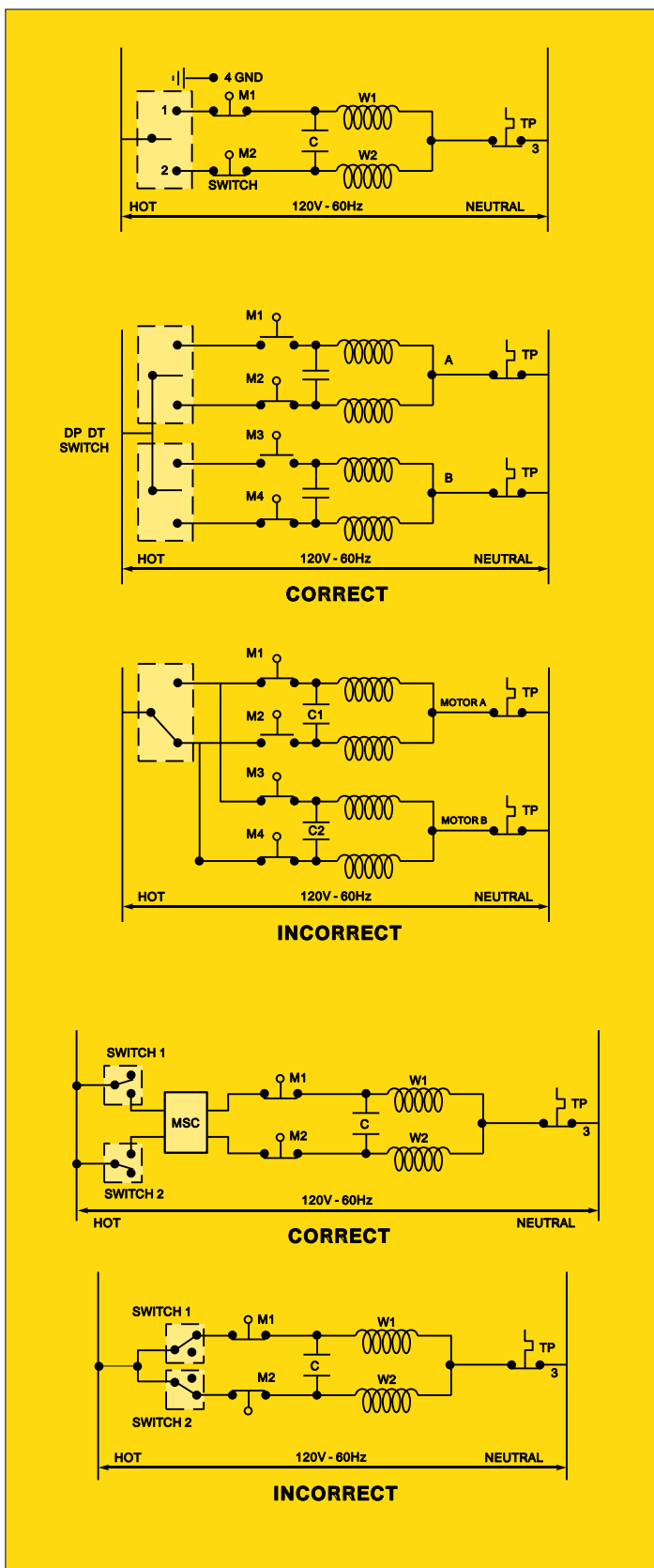



Catalog Number Index

Cat. No.	2005 No.	Description	Page
4000104		Stainless Steel M4 Socket Head Screw	57
4000551	670013	LT50 Motor Mounting Screws	49
4000555	100405A	LT50 RH Motor Mounting Screws	49
4000556	910065	ILT RH Motor Mounting Screws	49
4100122		Stainless Steel Lock Washer	57
4350026	9206033	Spring Ring	49
4350027	9910002	Locking Spring Ring	49
4350028	9206015	Pull-off Tool for Spring Ring	49
4350029	9206050	Cord Setting Tool	49
4350030	9685025	Spring Ring with Loop	49
4350031	9703956	Limit Switch Button Extensions	49
4350032	9910004	LT50 Stop Wheel	50
4350036		LT60 Stop Wheel	50
6020086		Tester Cable	50
6020087		FTS Tester Cable	50
6020500	9203859	LT Motor Cable 6 Ft. Long	51
6020501		LT Motor Cable 12 Ft. Long	51
6020502	9203812	LT Motor Cable 24 Ft. Long	51
6020505		LT Motor Cable 6 Ft. Long with Waterproof Plug	51
6020510	9208302	LT CMO Motor Cable 6 Ft. Long	55
6020511		LT CMO Motor Cable 12 Ft. Long	55
6020512	9208308	LT CMO Motor Cable 24 Ft. Long	55
6020515		LT CMO Motor Cable 6 Ft. Long with Waterproof Plug	55
6020540	9203886	LT Motor Cable - 6 Ft.	51
6020541	9203866	LT Motor Cable - 12 Ft.	51
6020542	9001264	LT Motor Cable - 24 Ft.	51
6020543	9203887	LT Motor Cable - 3 Ft.	51
6020544		LT Motor Cable - 18 Ft.	51
6020546		Plug-in Cable with 5-15P NEMA Plug - 3 Ft.	51
6020547		Plug-in Cable with 5-15P NEMA Plug - 6 Ft.	51
6020548		Plug-in Cable with 5-15P NEMA Plug - 12 Ft.	51
6020549		Plug-in Cable with 5-15P NEMA Plug - 24 Ft.	51
6020550	9000978	LT RTS CMO Motor Cable - 6 Ft.	55
6020551	9000979	LT RTS CMO Motor Cable - 12 Ft.	55
6020552	9000980	LT RTS CMO Motor Cable - 24 Ft.	55
6020554		LT RTS CMO Motor Cable - 18 Ft.	55
6020557		LT RTS CMO Cable with 5-15P Right Angle NEMA Plug - 6 Ft.	55
6020558		LT RTS CMO Cable with 5-15P Right Angle NEMA Plug - 12 Ft.	55
6020559		LT RTS CMO Cable with 5-15P Right Angle NEMA Plug - 24 Ft.	55
6020560		LT RTS CMO Cable with 5-15P Right Angle NEMA Plug - 18 Ft.	55
6020570		Plug-in Cable with 5-15P NEMA Plug - 18 Ft.	51
6050000	9163030	Adjustable Mechanical Stop (AMS)	30
6050001	9163252	Shaft Adaptor for 6 mm Hexagonal	30
6050002	9163253	Shaft Adaptor for 5 mm Square	30
6050003	9163251	Shaft Adaptor for 5 mm Hexagonal	30
6050004	9163268	Headrail Adaptor for Verosol Europe/Mexico	29
6050005	9163264	Headrail Adaptor for Classic Supreme®	29
6050006	9163265	Headrail Adaptor for MidiMatic®	29
6050007	9163262	Headrail Adaptor for SoftLine®	29
6050008	9163261	Headrail Adaptor for Fbr. 25 x 25mm	29
6050009	9163260	Headrail Adaptor for 25 x 25 mm/Celebrity/Best Buy	29
6050010	9163325	Headrail Adaptor for VersaRail/Easy Up/Activator/Easy Glide®	29
6050013	9163334	Headrail Adaptor for LightLines®	29
6050026		29 mm Round Tube (Max. 16 ft.)	31
6050029		29 mm Tube w/ "Grooved" Surface (max. 20 Ft.)	31



Cat. No.	2005 No.	Description	Page
6050040	9500687	LS 40 Intermediate Bracket	34
6050089		Fabric Clip for 40 mm Tube	35
6050090	9138028	Fabric Fastener for 2" (50 mm) O.D. Tube	50
6050102		Fabric Fastener for 2.5" (63 mm) O.D. Tube	50
6050129		45 x 51mm Extruded Aluminum White Headrail (max. 20 Ft.)	31
6050183		CTS 50 Headrail Mounting Brackets	50
6050184		CTS 50 Headrail Finished Side Caps	50
6050185		Headrail for CTS 50	50
6050186		Headrail Cover for CTS 50	50
6050256	9420673	Heavy Duty LT Intermediate Support Bracket	46
6050269	9701297	Light Duty LT50 Intermediate Support Bracket for a 2" Tube	46
6050290		Headrail Side Caps	31
6050326	9146071	63 x 1.5 mm (approx. 2.5") Tube Cord Take-up Reel	51
6050337	9146035	50 x 1.5 mm (approx. 2") Tube Cord Take-up Reel	51
6050347	9002541	LT50 Intermediate Bracket with 16 mm ID Bearing	46
6050360		LT50 Adjustable Intermediate Support Bracket for a 2" Tube	46
6050371		LT50 Adjustable Intermediate Support Bracket for a 2.5" Tube	46
6050400	9162258	Stop Collar Ring for 5 mm Hex Shaft	31
6050401	9162257	Stop Collar Ring for 6 mm Hex Shaft	31
6050403		Ladder Braid Crimps	30
6050406		5 mm Hex Shaft for CTS (16 Ft. Maximum Length)	31
6050407		6 mm Hex Shaft for CTS (7 Ft. Sections)	31
6050408		2" Slat Clips for Wood Blinds (White)	35
6050409		2" Slat Clips for Wood Blinds (Ivory)	35
6050410		2" Slat Clips for Wood Blinds (Brown)	35
6050411	1781078	Decorative Tape Adaptors for 1" Cotton Tape	31
6050412	1781079	Decorative Tape Adaptors for 1.5" Cotton Tape	31
6050438	9146011	Idler End Bearing Support for 16 mm Dia. Shaft	44
6050505		6 mm Hex Shaft for CTS (5 Ft. Sections)	31
6050517		2" Tube Take-up Reel	51
6050519		40 mm Tube Take-up Reel	51
6050521		40 mm Octagonal Tube	35
6050530	9410648	LT Intermediate Bracket for 2" Tube	46
6050600	9163338	Headrail Adaptor for GutterRail/Low Profile 2" Headrail	29
6050602		Headrail Adaptor for SureClose Headrail	29
6050650	9163331	Headrail Adaptor for EasyRise (New Version)	29
6050666	9163297	Wall Mount Brackets for RDS/RTS Control	30
6051001	9163255	Long Shaft Adaptor for 6 mm Hexagonal	30
6051003	9163254	Long Shaft Adaptor for 5 mm Hexagonal	30
6060158	9707031	2.75" Round LT50 Crown	52
6060181	9420342	2.75" Round LT60 Crown	52
6060306	9705340	70 mm Octagonal LT60 Crown	52
6060370	9751010	DS 70 LT Drive (1.2 -1.5 mm wall thickness)	53
6060394		P72 LT60 Crown	54
6060428	9707034	DS 70 LT50 Crown	53
6060473	9705341	DS 78 LT60 Crown	53
6060530	9520312	3.5" Round LT60 Crown	54
6060563	127797	3.5" Round LT50 Crown	54
6060585	9707037	DS 74 LT50 Crown	53
6060619	9707027	DS 78 LT50 Crown	53
6060653	9707024	I65 LT50 Crown	53
6060855	9707640	DS 78 / R LT60 Crown	53
6060877	9520356	4.0" Round LT60 Crown	54
6060934		4.0" Round LT60 Set	54
6061092	9690085	I85 LT60 Crown	54
6061115		I85 LT60 Set	54
6061126	9707639	DS 78 / D LT60 Crown	53
6061216	9705776	DS 85 LT60 Crown	53



Cat. No.	2005 No.	Description	Page
6061238		DS 85 LT50 Crown	53
6061284	9147544	LS40 Drive for (40 x 1.5 mm) Tube	36
6061285	9147330	LS40 Crown for (40 x 1.5 mm) Tube	36
6061286	9147545	LS40 Drive for (40 x 0.8 mm) Octagonal Tube	36
6061287	9147327	LS40 Crown for (40 x 0.8 mm) Octagonal Tube	36
6061288		LS40 40 mm Round Set	36
6061289		LS40 40 mm Octagonal Set	36
6061298	9162132	Flush Mount Bracket for LT28A and LT28B Motors	28
6061301	9705415	ABS Wheel-Left Rotation	51
6061302	9705414	ABS Wheel-Right Rotation	51
6061303	9706003	CMO ABS Wheel-Left Rotation	51
6061305	9706004	CMO ABS Wheel-Right Rotation	51
6061308	9500333	LS40 to LT50 Adaptor Kit	33
6061309	9132142	LS40 Drive for (40 x 1.0 mm) Tube	36
6061310	9132143	LS40 Crown for (40 x 1.0 mm) Tube	36
6061316	9206041	2.5" Round LT Drive (63 mm x 1.5 mm) - Soft Clip	52
6061317	9206019	2.5" Round LT Drive (63 mm x 1.5 mm) - Hard Clip	52
6061318	9206028	2.75" Round LT Drive (70 mm x 1.5 mm) - Hard Clip	52
6061319	9420301	3.5" Round LT Drive (89 mm x 1mm)	54
6061320	9420303	3.5" Round LT Drive (89 mm x 2 mm)	54
6061321	9420304	4.0" Round LT Drive (102 mm x 2 mm)	54
6061322	9761002	70 mm Octagonal LT Drive	52
6061323	9761011	P72 LT Drive	54
6061324	9761005	DS 78/R LT Drive	53
6061325	9761001	DS 78 LT Drive	53
6061326	9761004	DS 78/D LT Drive	53
6061327	9761003	DS 85 LT Drive	53
6061328	9420300	I85 LT Drive	54
6061331		70 mm Octagonal, Aluminum LT50/60 Drive Wheel Kit	52
6061350	9206089	2" Round LT50 Drive (50 mm x 1.5 mm) - Soft Clip	52
6061351	9206088	2" Round LT50 Drive (50 mm x 1.5 mm) - Hard Clip	52
6061352		2.5" Round LT50 Set - Hard Clip	52
6061353		2.75" Round LT50 Set	52
6061354	9206026	2.75" Round LT Drive (70 mm x 1.5 mm) - Soft Clip	52
6061355		60 mm Octagonal LT50 Set	52
6061356	9751001	60 mm Octagonal LT Drive	52
6061357		70 mm Octagonal LT50 Set	52
6061358		P72 LT50 Set	54
6061359		3.5" Round LT50 Set	54
6061360		DS 70 LT50 Set	53
6061361	9751005	DS 70 LT Drive (0.8 -1 mm wall thickness)	53
6061362		DS 74 LT50 Set	53
6061363	9751009	DS 74 LT Drive	53
6061364		DS 78 LT50 Set	53
6061365	9751004	I65 LT50 Drive	53
6061366		I65 LT50 Set	53
6061368	9707030	SM 65 LT50 Crown - 3 grooves	54
6061369	9751002	SM 65 LT Drive	54
6061374	9910052	AMA71 LT50 Drive	54
6061375		AMA71 LT50 Crown	54
6061376	9762012	LT60 Crown (78 mm Dia.)	54
6061377	9761012	LT60 Drive (78 mm Dia.)	54
6061380	9704080	2" LT Drive for CTS 50 Tube	54
6061385	9705345	50 mm Octagonal LT50 Crown	52
6061386	9705344	50 mm Octagonal LT50 Drive	52
6061400		2.75" Round LT60 Set	52
6061401		70 mm Octagonal LT60 Set	52
6061402		3.5" Round LT60 Set	54



Cat. No.	2005 No.	Description	Page
6061414	9707026	2.5" Round LT50 Crown	52,53
6061415	9707025	60 mm Octagonal LT50 Crown	52
6070003		LT50 Motor Angle Bracket	37
6070029		Molded LT28 Motor/Idler Brackets	31
6070040	9500683	LS40 Radial Square Motor Bracket	34
6070082	9410665	Universal LT50 Motor Bracket (LS Style)	37
6070138	9510658	"U" Shape LS Style Motor Bracket	37
6070182	9701091	Heavy Duty Angle Plate	37
6070188		CTS 50 Motor Bracket	42
6070238	9701309	LT50 Round Anti-Vibration Motor Bracket	37
6070256	9430601	Motor Bracket LT60 FTS	37
6070284	9410639	LT50 Angle Plate with Elongated Holes Allowing Adjustment	38
6070418	9147334	LS40 "Lo" Bracket with a Square Stud	33
6070427		LS40 Motor Bracket	33
6070429	9500659	LS40 to LT50 Motor Mounting Conversion Bracket	33
6070446		LT50/60 Motor Bracket with 1/2" Conduit Connector	38
6070499	9910021	Universal Bracket with Spring Ring	38
6070500	9206029	Weld-on Bracket Without Spring Ring	38
6070501	9420631	Universal Bracket with Spring Ring -Zamak Material	38
6070502	9910001	Universal Bracket With Spring Ring and Metric Molded Nuts	38
6070504	9420642	Heavy Duty Angle Plate with Universal Motor Bracket	39
6070506	9420604	Heavy Duty Angle Plate	39
6070507	9763503	Motor Bracket With Spring Ring (120 mm x 120 mm)	39
6070509	9002550	LT50 Adjustable Universal Motor Bracket	40
6070510	9763508	Motor Bracket With Spring Ring (100 mm x 100 mm)	39
6070511	9420620	LT50/60 Radial Motor Bracket	40
6070513	9410651	LT50 Universal Motor Bracket	40
6070515	9206020	Retrofit Brackets Pin Hole Vertical	40
6070516	9206021	Retrofit Brackets Pin Hole Horizontal	40
6070517	9410612	"Lo" LT50 Motor Bracket	40
6070518	9703948	Adjustable Motor Bracket with Spring Ring	41
6070519	9410715	LT50 HA Motor Bracket	41
6070521	9910011	LS40 and LT50 RH "LO" Bracket with Round Hole	33
6070522	9910016	LT RH Motor Bracket with Vertical Pin Hole	41
6070523	9910017	LT RH Motor Bracket with Horizontal Pin Hole	41
6070524	9704029	LT60 Retrofit Bracket with Spring Ring	41
6070525	9707082	LT Motor Bracket with a Square 16 x 16 mm Stud	41
6070526	9410637	LT50 Angle Bracket	42
6070527	9410739	LT50 Anti-Vibration Motor Bracket	42
6070528	9701331	LT50 Anti-Vibration Motor Bracket	42
6080029		Headrail Mounting Brackets	31
6080040	9500685	LS40 Idler Bracket for 8 mm Shaft	34
6080105		Idler Bracket 10 mm Ball Bearing and Holder Kit	43
6080116	9132065	Heavy Duty Idler Bracket	43
6080138	9410803	Nylon Ball Bearing with 10 mm ID	43
6080149	1781030	Ball Bearing Holder	43
6080183		CTS 50 Headrail Mounting Bracket	50
6080189		CTS 50 Motor Idler Bracket	43
6080206	9701310	LT50 Round Anti-Vibration Motor Bracket	43
6080218	9002540	LT50 Idler Bracket with 14 mm ID Bearing	43
6080239	9146007	Idler End Bearing Support for 14 mm dia. shaft (no hardware)	44
6080241	9028665	Nylon Ball Bearing with 12 mm ID	43
6080250	9430610	Idler End Nylon 12 mm Ball Bearing with Holder	44
6080251	9500736	LS40 Motor/Idler Bracket for 2" x 2 1/4" GutterRail Headrail	35
6080254	9410635	LT50 Idler Bracket with Nylon Bearing (for 10 mm Shaft)	43
6080255	9410633	LT50 Idler Bracket with Nylon Bearing (for 12 mm Shaft)	43
6080256	9430603	Heavy Duty Idler Bracket with Idler End Cap Holder	45
6080257	9540786	Idler End Cap Holder	45



Cat. No.	2005 No.	Description	Page
6080262	9002519	White Dress Cover for Idler and Motor Brackets	44
6080526	9701333	LT50 Anti Vibration Idler Bracket (for 10 mm shaft)	45
6080527	9410740	Anti-vibration Idler Bracket for 12 mm Diameter Shaft	45
6080528	9127808	"U" Shaped Idler Bracket	45
6080529	1781015	Idler Bearing for 12 mm Diameter Shaft	45
6090005	9128101	Die Cast End Cap with 10 mm Shaft	47
6090016	9701380	2" Anti-Vibration End Cap	47
6090027	9701116	Molded Composite End Cap (2.5" Tube Diameter)	47
6090040	9500688	LS 40 Idler End Cap with 8 mm Diameter Pin	34
6090072	9700958	Molded Composite End Cap (2.0" Tube Diameter)	47
6090094	9129643	2" Tube Adjustable End Cap with 12 mm Diameter Shaft	47
6090106	9129644	2.5" Tube Adjustable End Cap with 12 mm Diameter Shaft	47
6090139	9132038	2" Tube Adjustable End Cap with 14 mm Diameter Shaft	47
6090140	9132040	2.5" Tube Adjustable End Cap with 14 mm Diameter Shaft	47
6090151	9132041	2.75" Tube Adjustable End Cap with 14 mm Diameter Shaft	47
6090162	9129631	2" Tube Idler End Cap without Shaft	47
6090173	9129632	2.5" Tube Idler End Cap without Shaft	47
6090184	9129633	2.75" Tube Idler End Cap without Shaft	47
6090185	9137018	40 x 0.6 mm Octagonal Tube End Cap	34
6090186		40 x 1.1 mm Octagonal Tube End Cap	34
6090190		Idler End Cap for CTS 50 Tube	48
6090195	1781009	13 mm Square Drive Shaft with 12 mm Diameter Shaft	48
6090207	1781011	13 mm Square Drive Shaft with 14 mm Diameter Shaft	48
6090256	9420674	Heavy Duty End Cap Shaft	48
6090285	9132087	Die Cast End Cap with 12 mm Shaft	47
6090307		40 mm Diameter Adjustable End Cap	33
6090315	9020000	End Cap for 29 mm Tube	28, 31
6090318	9701288	Roller Tube End Cap with 12 mm Hole	48
6090323	9420800	Universal End Cap for 2" Tube with 10 mm Collapsible Shaft	48
6090324	9420801	Universal End Cap for 2" Tube with 12 mm Collapsible Shaft	48
6090325	9420802	Universal End Cap for 2" Tube with 14 mm Collapsible Shaft	48
6110500		Standard LT and LT CMO Motor Mounting Plate	55
6110501	9708549	CMO 100 x 100 mm LT Motor Mounting Bracket	55
6180001		US 3/4 inch SS Hardware Kit	59
6180002		US 1 inch SS Hardware Kit	59
6180003		US 1.25 inch SS Hardware Kit	59
6180005		Metric 20 mm SS Hardware Kit	59
6180006		Metric 25 mm SS Hardware Kit	59
6180007		Metric 30 mm SS Hardware Kit	59
6180029		CTS 29mm w/New Molded Cradle Kit for SOMFY 46 x 51mm Headrail	31, 32
6180353	9030000	Angle Brackets w/Teflon Bushings	28
6180354	9030030	Angle Brackets w/Plastic Caps	28
6180356		Standard Brackets	28
6180367		29mm Cone and Ring Kit	32
6180389		CTS 25 (Kit) for Standard 1"x1" Headrail (5 mm Hex Shaft)	32
6180391		CTS 40 (Kit) for GutterRail 2" x 2 1/4" Headrail	34
6180393		CTS 25 (Kit) for Standard 1"x1" Headrail (5 mm Square Shaft)	32
6180394		CTS 25 (Kit) for Classic Supreme® Headrail (6 mm Hex Shaft)	32
6180395		CTS 25 (Kit) for Standard 1"x1" Headrail (6 mm Hex Shaft)	32
6180396		CTS 25 (Kit) for Classic Supreme® Headrail (5 mm Hex Shaft)	32
6180397		CTS 25 (Kit) for VersaRail/Easy-Up/EasyGlide® (5 mm Hex Shaft)	32
6180398		CTS 25 (Kit) for VersaRail/Easy-Up/EasyGlide® (6 mm Hex Shaft)	32
6180404		CTS 25 (Kit) for GutterRail/Low Profile 2" Headrail (5 mm Hex Shaft)	32
6180405		CTS 25 (Kit) for GutterRail/Low Profile 2" Headrail (6 mm Hex Shaft)	32
6180407		CTS 25 (Kit) for LightLines® (5 mm Hex Shaft)	32
6180408		CTS 25 (Kit) for LightLines® (6 mm Hex Shaft)	32
6180451		LT50 Flexible Intermediate Bracket Kit for 2" Tube (30 Degree Bend)	46
6180452		LT50 Flexible Intermediate Bracket Kit for 2" Tube (45 Degree Bend)	46



Cat. No.	2005 No.	Description	Page
6180497		CTS 25 (Kit) Short Cones for VersaRail Headrail (5 mm Hex Shaft)	32
6180498		CTS 25 (Kit) Short Cones for VersaRail Headrail (6 mm Hex Shaft)	32
6180500		CTS 50 (Kit)	50
6180600		CTS 25 (Kit) for EasyRise [®] (New Version) Headrail (5 mm Hex Shaft)	32
6180601		CTS 25 (Kit) for EasyRise [®] (New Version) Headrail (6 mm Hex Shaft)	32
6180700		CMO Round Awning Override Kit	60
6180701		CMO ME Square Awning Override Kit	60
6250500	208101A	LT50 Manual Override Differential	55
6250505	9910046	LT50 Differential Torque Tube Connectors (Square Link Bars)	55
6250506	9910045	LT50 Differential Torque Tube Connectors (Round Link Bars)	55
6250685	9910019	CMO Motor Limit Setting Tool	56
6250700	9420648	CMO Round Awning Motor Bracket	56
6250701	9910041	CMO Square ME Motor Bracket	56
6250702	9910051	CMO Motor Bracket	57
6250710	9685114	CMO Awning Eye with 2.36" (60 mm) Long 7 mm Hex Shaft	57
6250711	9685136	CMO Awning Eye with 6.5" (165 mm) Long 7 mm Hex Shaft	57
6250712	9707287	LT CMO Awning Eye Compatible with Geiger Crank Handles	57
6250713	9685148	CMO Awning Eye with 4" (100 mm) Long 7 mm Hex Shaft	57
6250715	9420657	CMO Extension Shafts (8.66" Long)	57
6250716	9420659	CMO Extension Shafts (13" Long)	57
6250717	9685118	Connecting Sleeves (7 mm hex. to 11.3 mm diameter)	57
6250718		Connecting Sleeves (7 mm hex. to 8 mm square)	57
6250719	9685120	Connecting Sleeves (7 mm hex. to 7 mm hex.)	57
6250720	9685174	CMO Extension Shaft with Universal Joint	57
6250721	9685180	CMO Extension Shaft with Awning Eye and Plate	58
6250723		LT CMO 70 Degree, 4 Hole Plate SS Crank Handle Universal Joint	58
6250724		LT CMO 90 Degree, 2 Hole Plate SS Crank Handle Universal Joint	58
6250725		LT CMO 90 Degree, 4 Hole Plate SS Crank Handle Universal Joint	58
6250730		7 mm Hex to 7 mm Hex Universal Joint Adaptor	58
6250731		7 mm Hex to 8 mm Square Universal Joint Adaptor	58
6250732		7 mm Hex to 8 mm Square Double Universal Joint Adaptor	58
9060271		70 mm Octagonal LT50 Crown	52
9060338		P72 LT50 Crown Set	54
9080239		Idler End Bearing Support for 14 mm Diameter Shaft	44
9250700		CMO Awning Kit without Awning Eye	60
9250701		CMO ME Awning Kit without Awning Eye	60